

Brochure 21/22
Easy to drive

Variable Speed Drives

SD

75

0

Page. 4 – 5

PE genetics

CONTENTS

Our products

Page. 6 – 47

Page. 48 – 50

Our secret

Energy efficiency for every situation

We handle everything in-house: from design and manufacture to testing.

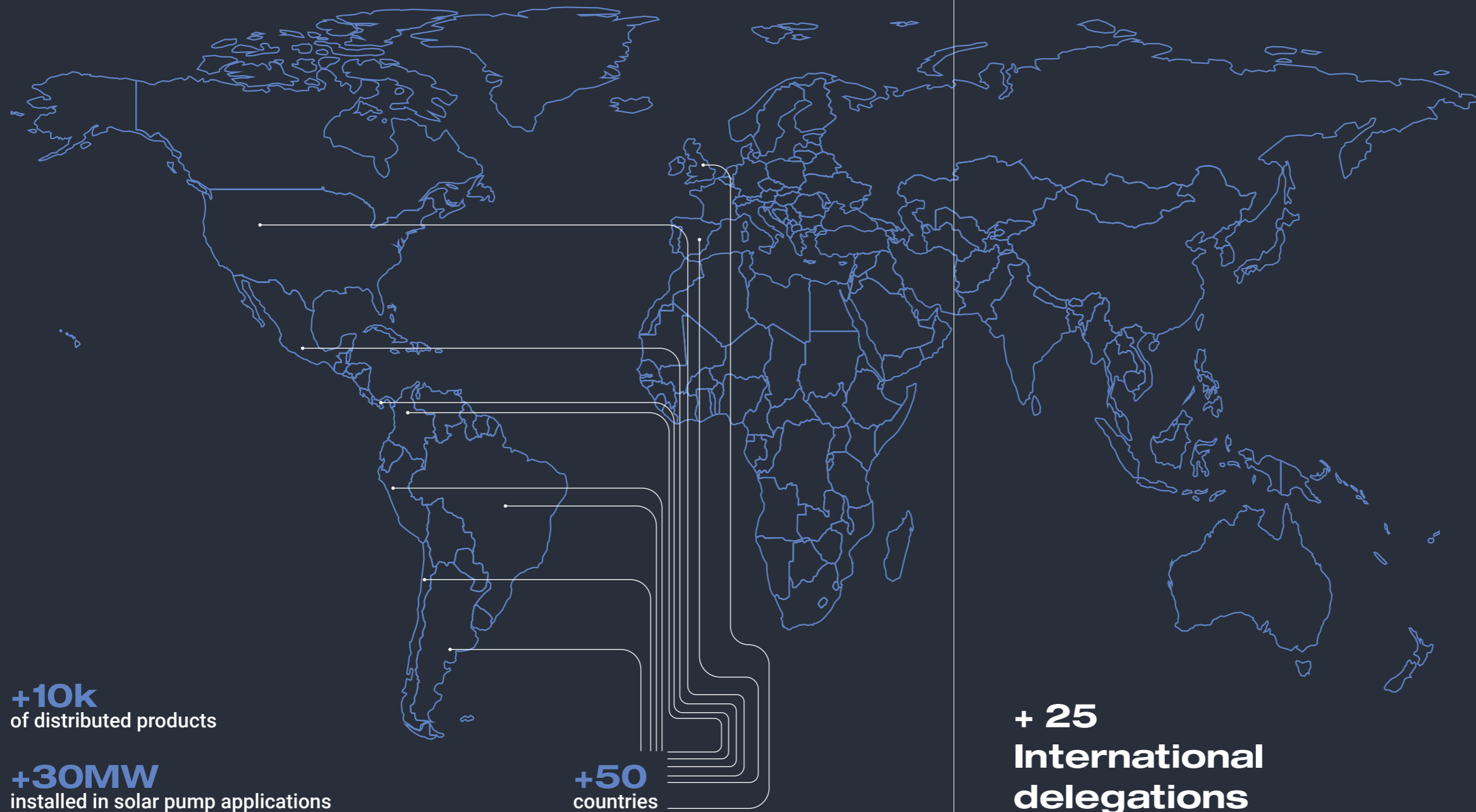

More than

+ 50 _{GW}
of installed
AC power
Solar + Storage

+ 25 _{GW}
of annual
production
capacity

+ 30
years of
excellence

**“Vertical
integration gives
us flexibility**

SD

750
**to adapt to
customers’
requirements”**

Page. 10 – 23

SD750
VARIABLE

Page. 24 – 29

SPEED SD750SP

Page. 30 – 37

SD750FR
DRIVES

Page. 38 – 47

SD750K

SD750

The core of the family

SD750 is the most flexible and extensive series with a compact design for easy installation, commissioning and maintenance.



1,5kW - 2200kW



380-690Vac



Up to 50°C



All our equipment share the following characteristics

1 Full frontal access

Maintenance and cleaning reduce company yield, therefore SD750 has been designed with the latest engineering good practices to reduce time, spare parts cost and to increase availability.

2 Low dV/dt and RFI filter

SD750 includes built-in as standard dV/dt filter that reduces the dV/dt value to 500-800V/ μ s depending on the drive size and rated voltage, minimizing the voltage peaks at the motor winding. It is the unique drive in the market focused on the customer's needs such as wiring and motor cost reduction.

3 Harmonics filter

High input impedance given by the 3% input chokes protects the drive against any grid anomaly and enhances its THDi performance in weak grids.

4 Higher power density

With an advanced smart design, we have developed a highpower drive with a smaller compact solution that is able to be integrated in any application.

Following our reliability philosophy of oversizing critical components, the SD750 series will provide you a reliable and powerful compact solution for easy installation, commissioning and maintenance.

5 Innovative Cooling System

SD750 truly offers operation up to 50°C due to oversized heat sinks with a junction temperature below 100°C and no power derating.

Moreover, we adapt our products to worldwide operation under the most adverse conditions without supervision. We achieve this due to multiple internal temperature sensors and oversized heatsinks.

LEVEL 1 Electronics

The electronic components are completely isolated in what is called the “electronics area”. The heat exchange of the electronic components is separated from the areas that cool the heat sink and the electric filtering components, making the cooling of these components much more efficient.

LEVEL 2 Cooling

SD750 cooling system uses efficient axial fans at low speed which provide three main benefits:

- The internal dust deposition ratio in polluted environments (cement, mining, minerals, metal industry, etc) is significantly decreased at low air speeds, therefore the maintenance frequency is reduced.
- The internal air pressure losses are reduced exponentially, increasing cooling system efficiency.
- The sound levels are reduced in order to favour a comfortable operation.

LEVEL 3 Input filter

The input filters are enclosed separately, optimizing their cooling capacity, degree of protection and increasing their long life operation.



6 Connectivity

SD750 is compatible with the most used industrial protocols in the market. Incorporating Modbus RTU and Modbus TCP protocols as standard and as an option Ethernet/IP, Profibus and ProfiNet.

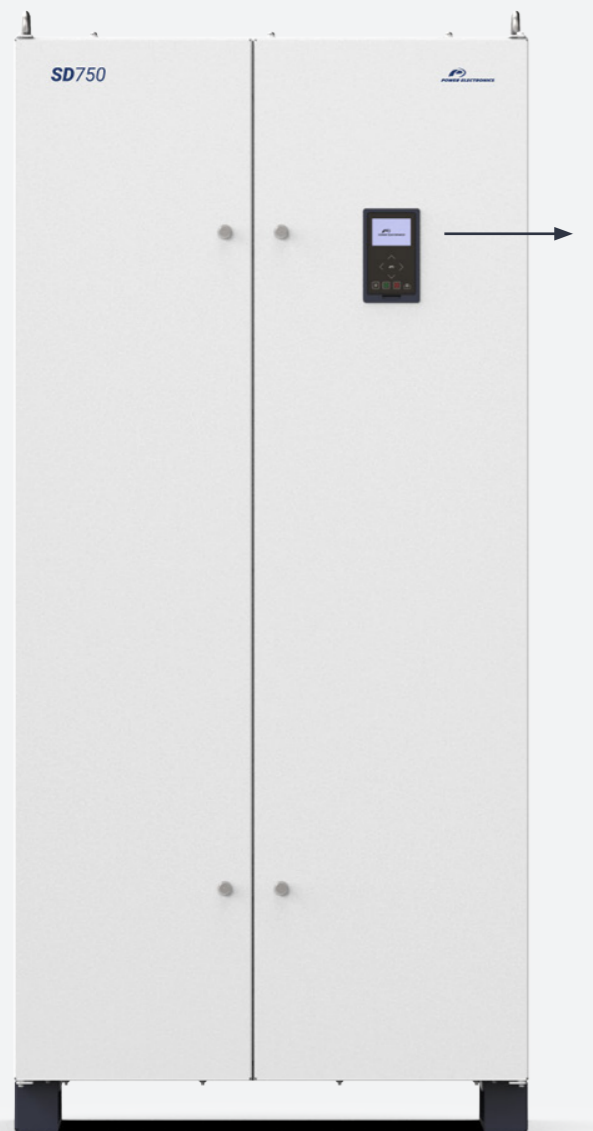

- Control and push buttons
- Display
- Multiple drives synchronization applications
- Output filters and equipment
- Digital inputs
- Output relays
- Analogue inputs and outputs
- Comparators

8 Advanced Motor Control

Power Electronics' success is measured by our customer's satisfaction. The motor control systems developed by Power Electronics have been designed to meet the most demanding features. The SD750 integrates V/f control and two vector controls: Power Motor Control (PMC) and the Advanced Vector Control (AVC) as standard.

7 Maximum safety

With motor relay features built-in as standard the SD750 hardware offers continuous monitoring of the motor electric values and its temperature (PTC sensor, and PT100). As a result, the highly advanced software provides full motor and drive protection.

9 Dedicated software tools and macros

The lessons learned from many customers and working closely with them have allowed Power Electronics to design of the most flexible tools for user customization and process monitoring.

With a wide range of ready-made macros to optimize any application productivity and usability and being customizable to meet the precise application needs of every customer. The SD750 series monitors the real performance information about motor and drive status integrating an accurate power grid analyzer and drive diagnosis.

SD750

INPUT	Power range ^[1]	1.5kW – 2200kW	
	Voltage range	380 – 480Vac (±10%), 525 – 690Vac (-5/+10%)	
	Input frequency	50 Hz / 60 Hz (± 6%)	
	Input rectifier technology	Diode-Diode F1-F2/Thyristor-Diode F3-F11 (multipulse available ^[1])	
	Displacement power factor (DPF = cos Φ)	≥ 0.98	
	Power factor (PF= I ₁ / I _{rms} · cos Φ)	≥ 0.91	
	Momentary power loss	> 2 seconds (depending on the load inertia)	
	EMC input filter	Second environment (Industrial): C3 Standard. First environment (Domestic): C2 (Optional), C1 consult with Power Electronics. IT filter optional	
	Harmonics filter	Choke coils 3% impedance	
	Current THD (%)	< 40%	
	Regenerative	No	
	OUTPUT	Output frequency ^[2]	0... 599 Hz
		Overload capacity	Constant torque / heavy duty: 150% during 60 seconds at 50°C Variable torque / normal duty: 120% during 60 seconds at 40°C
		Efficiency (at full load)	≥ 98%
		V / Hz	
Control method		VECTOR CONTROL Open Loop: PMC speed / torque control, AVC: speed / torque control Close Loop (Encoder): PMC speed / torque control, AVC: speed / torque control PMSM I/f & Sensorless and HEPOL (High Efficiency Performance Open Loop)	
Carrier frequency		4 to 8 kHz - PEWave	
Output dV/dt filter		500 - 800 V/μs	
Output cable length ^[4]		USC 300 m - SC 150 m	
Dynamic brake		External B150 Dynamic Brake - (Frames 1 and 2 integrated)	
ENVIRONMENTAL CONDITIONS		Operation ambient temperature	Minimum: -20°C Maximum: +50°C (Heavy duty) Minimum: -20°C Maximum: +40°C (Normal duty)
	Storage temperature	Minimum: -40°C Maximum: +70°C	
	Altitude	1000 m	
	Power altitude derating ^[1]	>1000m, 1% P _N (kW) per 100m; 4000m maximum (for higher altitude consult with PE)	
	Ambient humidity	<95%, non-condensing	
	Degree of protection	IP20 ^[5] , IP54 ^[6] , IP42 ^[7] , Marine series adapted (IP44/IP54, under request)	
	Vibration	Amplitude: ± 1mm (2 Hz-13.2 Hz), ± 0.075 mm (13.2 Hz-57 Hz) Acceleration: 6.86 m/s ² (13.2 Hz-57 Hz), 9.8 m/s ² (57 Hz-150 Hz)	
	Heating resistors	Optionals	
PROTECTIONS	Motor protections	Rotor locked, Motor overload (thermal model), Output current limit, Phase current imbalance, Phase voltage imbalance, Motor over-temperature (PT100 signal), Speed limit, Torque limit	
	Drive protections	IGBT's overload, Input phase loss, Low input voltage, High input voltage, DC Bus voltage limit, Low DC Bus voltage, IGBT temperature, Heat-sink over-temperature, Power supply fault, Drive thermal model, Ground fault, Software and Hardware fault, Analogue input signal loss (speed reference loss), Safe stop/Emergency Stop	

HARDWARE	Digital inputs	6 programmable, Active high (24 Vdc), Isolated power supply	
	Digital outputs	3 programmable changeover relays (250 Vac, 8 A or 30 Vdc, 8 A)	
	Analogue input	3 programmable differential inputs: 0-20 mA, 4-20 mA, 0-10 Vdc and ±10 Vdc. PT100. (Optically isolated).	
	Analogue outputs	2 isolated programmable outputs: 0-20 mA, 4-20 mA, 0-10 Vdc and ±10 Vdc	
	Encoder inputs (optional)	1 differential encoders input. Voltages inputs from 5 to 24Vdc	
	User power supply	+24 Vdc user power supply (Max. 180 mA) regulated and short-circuit protected +10 Vdc user power supply (Max. 2 potentiometers R=1 kΩ) regulated and short-circuit protected	
	I/O Extension board (optional)	Digital I/O board: 5 Digital inputs: Programmable inputs and active high (24Vdc). Optically isolated 5 Digital outputs: programmable multi-function relays Analogue I/O board: 2 Analogue input: Programmable and differential input 2 Analogue output: Programmable outputs in voltage/current	
	External power supply (optional)	24 V External power supply integrated	
	SD card	Port for an external SD Card. Data Logging, events registration	
	COMMUNICATION	Standard hardware	USB port RS485 port Ethernet
Optional hardware		Optical fibre Communication boards	
Standard protocol		Modbus-RTU Ethernet (Modbus TCP)	
Optional protocol		Profibus-DP Ethernet IP ProfiNet	
CONTROL PANEL	Type	Removable	
	Length	3 meters (optional)	
	Connection	USB	
	Visualization leds	LED RUN: Motor receiving power supply LED FAULT: Flashing displays that a fault has occurred	
	LCD display	LCD screen Keypad with 8 keys to control and configure the drive, start and stop/reset Independent memory	
	Display information	Average current and 3-phase motor current Average voltage and 3-phase motor voltage Average input voltage and 3-phase input voltage 3-phase input and output frequency DC Bus Voltage	
	Others	Drive status Speed, Torque, Power, Power factor of motor Register of total and partial drive running time with reset function. (hours) Register of total and partial drive energy consumption with reset function (kWh) Relay status Digital inputs / PTC status Output comparator status Analogue inputs and sensor values Analogue output value Motor overload and equipment status Drive and rectifier temperature Fault history (last 6 faults) Real time clock Perpetual calendar	
	REGULATIONS	Certifications	CE, cTick, UL, cUL, Marine certifications (under request)
		Electromagnetic compatibility	EMC Directive (2004/108/CE) IEC/EN 61800-3
		Design and construction	LVD Directive (2006/95/CE) IEC/EN 61800-2 General requirements IEC/EN 61800-5-1 Safety IEC/EN 60146-1-1 Semiconductor converters IEC60068-2-6 - Vibration
Functional safety		IEC/EN 61800-5-2 Safety Stop (STO)	

NOTES

[1] Consult availability with Power Electronics.

[2] For operation frequencies higher than 100 Hz, consult Power Electronics.

[3] Valid for frames 3 to 11 depending on the SD750 rated power. For frames 1 and 2 it is available optional filter.

[4] SC: Shielded cable, USC: Unshielded Cable. Follow Power Electronics installation recommendations. For greater cable lengths, consult Power Electronics.

[5] Available for 380–480Vac up to frame 4.

[6] Applicable to the electronics.

[7] For stand-alone models.

SD750 CONFIGURATION TABLE

SD750 SERIES		ND OUTPUT CURRENT		A INPUT VOLTAGE		B DEGREE OF PROTECTION		C GROUNDING CONNECTION		D > 4000 METER (above sea level)	
SD750S	SD750 Standard	0003	3 A	5	380-480 Vac	2	IP20	S	TT/TN	S	Not needed
		6	525-690 Vac	5	IP54	T	IT	A	Needed
		3100	3100 A			4	IP42				

SD750 STANDARD RATINGS

FRAME	CODE	Operation temperature 40°C NORMAL DUTY			Operation temperature 50°C HEAVY DUTY			OVERLOAD (A)
		Motor power (kW)	Motor power (hp)	I(A) Rated	Motor power (kW)	Motor power (hp)	I(A) Rated	
1	SD75S0006 5BCD	2.2	3	6	1.5	2	3	6
	SD75S0008 5BCD	4	5	8	2.2	3	6	9
	SD75S0011 5BCD	5.5	7,5	11	4	5	9	14
	SD75S0015 5BCD	7.5	10	15	5.5	7,5	12	18
	SD75S0024 5BCD	11	15	24	7.5	10	18	27
	SD75S0030 5BCD	15	20	30	11	15	24	36
	SD75S0040 5BCD	18.5	25	40	15	20	32	48
2	SD75S0048 5BCD	22	30	48	18.5	25	38	57
	SD75S0060 5BCD	30	40	60	22	30	48	72
	SD75S0075 5BCD	37	50	75	30	40	60	90
3	SD75S0095 5BCD	45	60	95	37	50	75	113
	SD75S0110 5BCD	55	75	110	45	60	90	135
	SD75S0145 5BCD	75	100	145	55	75	115	173
	SD75S0180 5BCD	90	125	180	75	100	150	225
4	SD75S0200 5BCD	110	150	200	90	125	170	255
	SD75S0260 5BCD	132	200	260	110	150	210	315
5	SD75S0320 5BCD	160	250	320	132	200	250	375
	SD75S0400 5BCD	220	300	400	160	250	330	495
6	SD75S0450 5BCD	250	350	450	220	300	370	555
	SD75S0570 5BCD	315	400	570	250	350	460	690
	SD75S0700 5BCD	400	550	700	315	450	580	870
7	SD75S0800 5BCD	450	650	800	355	500	650	975
	SD75S0900 5BCD	500	700	900	400	550	720	1080
	SD75S1050 5BCD	560	800	1050	450	700	840	1260
8	SD75S1140 5BCD	630	900	1140	500	750	925	1388
	SD75S1400 5BCD	800	1000	1400	630	900	1150	1725
>8	SD75S1550 5BCD	900	1250	1550	710	1000	1260	1890
	SD75S1800 5BCD	1000	1400	1800	800	1150	1440	2160
	SD75S1950 5BCD	1100	1500	1950	900	1250	1580	2370
	SD75S2250 5BCD	1200	1750	2250	1000	1450	1800	2700
	SD75S2750 5BCD	1500	2200	2750	1200	1750	2200	3300
	SD75S3100 5BCD	1750	2450	3100	1400	2000	2500	3750

POWER RANGE AT 400VAC

FRAME	CODE	Operation temperature 40°C NORMAL DUTY			Operation temperature 50°C HEAVY DUTY			OVERLOAD (A)
		Motor power (kW)	Motor power (hp)	I(A) Rated	Motor power (kW)	Motor power (hp)	I(A) Rated	
1	SD75S0006 5BCD	2.2	3	5	1.5	2	3	6
	SD75S0008 5BCD	4	5	7	2.2	3	5	8
	SD75S0011 5BCD	5.5	7,5	10	4	5	8	13
	SD75S0015 5BCD	7.5	10	14	5.5	7,5	11	16
	SD75S0024 5BCD	11	15	22	7.5	10	16	25
	SD75S0030 5BCD	15	20	27	11	15	22	33
	SD75S0040 5BCD	18.5	25	36	15	20	29	44
2	SD75S0048 5BCD	22	30	44	18.5	25	35	52
	SD75S0060 5BCD	30	40	55	22	30	44	65
	SD75S0075 5BCD	37	50	68	30	40	55	82
3	SD75S0095 5BCD	45	60	86	37	50	68	103
	SD75S0110 5BCD	55	75	100	45	60	82	123
	SD75S0145 5BCD	75	100	132	55	75	105	157
	SD75S0180 5BCD	90	125	164	75	100	136	205
4	SD75S0200 5BCD	110	150	182	90	125	155	232
	SD75S0260 5BCD	132	200	236	110	150	191	286
5	SD75S0320 5BCD	160	250	291	132	200	227	341
	SD75S0400 5BCD	220	300	364	160	250	300	450
6	SD75S0450 5BCD	250	350	409	220	300	336	505
	SD75S0570 5BCD	315	400	518	250	350	418	627
	SD75S0700 5BCD	400	550	636	315	450	527	791
7	SD75S0800 5BCD	450	650	727	355	500	591	886
	SD75S0900 5BCD	500	700	818	400	550	655	982
8	SD75S1050 5BCD	560	800	955	450	700	764	1145
	SD75S1140 5BCD	630	900	1036	500	750	841	1262
	SD75S1400 5BCD	800	1000	1273	630	900	1045	1568
>8	SD75S1550 5BCD	900	1250	1409	710	1000	1145	1718
	SD75S1800 5BCD	1000	1400	1636	800	1150	1309	1964
	SD75S1950 5BCD	1100	1500	1773	900	1250	1436	2155
	SD75S2250 5BCD	1200	1750	2045	1000	1450	1636	2455
	SD75S2750 5BCD	1500	2200	2500	1200	1750	2000	3000
	SD75S3100 5BCD	1750	2450	2818	1400	2000	2273	3409

POWER RANGE AT 440VAC

STANDARD RATINGS

FRAME	CODE	Operation temperature 40°C			Operation temperature 50°C			OVERLOAD (A)
		NORMAL DUTY			HEAVY DUTY			
		Motor power (kW)	Motor power (hp)	I(A) Rated	Motor power (kW)	Motor power (hp)	I(A) Rated	
1	SD75S0006 5BCD	2.2	3	5	1.5	2	3	6
	SD75S0008 5BCD	4	5	7	2.2	3	5	8
	SD75S0011 5BCD	5.5	7,5	9	4	5	8	12
	SD75S0015 5BCD	7.5	10	13	5.5	7,5	10	15
	SD75S0024 5BCD	11	15	20	7.5	10	15	23
	SD75S0030 5BCD	15	20	25	11	15	20	30
	SD75S0040 5BCD	18.5	25	33	15	20	27	40
2	SD75S0048 5BCD	22	30	40	18.5	25	32	48
	SD75S0060 5BCD	30	40	50	22	30	40	60
	SD75S0075 5BCD	37	50	63	30	40	50	75
3	SD75S0095 5BCD	45	60	79	37	50	63	94
	SD75S0110 5BCD	55	75	92	45	60	75	113
	SD75S0145 5BCD	75	100	121	55	75	96	144
	SD75S0180 5BCD	90	125	150	75	100	125	188
4	SD75S0200 5BCD	110	150	167	90	125	142	213
	SD75S0260 5BCD	132	200	217	110	150	175	263
5	SD75S0320 5BCD	160	250	267	132	200	208	313
	SD75S0400 5BCD	220	300	333	160	250	275	413
6	SD75S0450 5BCD	250	350	375	220	300	308	463
	SD75S0570 5BCD	315	400	475	250	350	383	575
	SD75S0700 5BCD	400	550	583	315	450	483	725
7	SD75S0800 5BCD	450	650	667	355	500	542	813
	SD75S0900 5BCD	500	700	750	400	550	600	900
	SD75S1050 5BCD	560	800	875	450	700	700	1050
8	SD75S1140 5BCD	630	900	950	500	750	771	1157
	SD75S1400 5BCD	800	1000	1167	630	900	958	1438
	SD75S1550 5BCD	900	1250	1292	710	1000	1050	1575
>8	SD75S1800 5BCD	1000	1400	1500	800	1150	1200	1800
	SD75S1950 5BCD	1100	1500	1625	900	1250	1317	1975
	SD75S2250 5BCD	1200	1750	1875	1000	1450	1500	2250
	SD75S2750 5BCD	1500	2200	2292	1200	1750	1833	2750
	SD75S3100 5BCD	1750	2450	2583	1400	2000	2083	3125

POWER RANGE AT 480VAC

FRAME	CODE	Operation temperature 40°C			Operation temperature 50°C			OVERLOAD (A)
		NORMAL DUTY			HEAVY DUTY			
		Motor power (kW)	Motor power (hp)	I(A) Rated	Motor power (kW)	Motor power (hp)	I(A) Rated	
4 [1]	SD75S0055 6BCD	37	50	55	30	40	42	63
	SD75S0065 6BCD	45	60	65	37	50	52	78
	SD75S0075 6BCD	55	75	75	45	60	62	93
	SD75S0100 6BCD	75	100	100	55	75	80	120
	SD75S0120 6BCD	90	125	120	75	100	105	157
5	SD75S0160 6BCD	110	150	160	90	125	130	195
	SD75S0180 6BCD	132	180	180	110	150	150	225
	SD75S0210 6BCD	150	200	210	132	180	170	255
6	SD75S0250 6BCD	185	250	250	150	200	210	315
	SD75S0310 6BCD	220	300	310	185	250	260	390
7	SD75S0400 6BCD	280	400	400	220	300	320	480
	SD75S0480 6BCD	355	450	480	280	400	385	578
8	SD75S0570 6BCD	400	550	570	355	450	460	690
	SD75S0680 6BCD	500	650	680	400	550	550	825
>8	SD75S0825 6BCD	560	800	825	500	650	660	990
	SD75S0930 6BCD	630	900	930	560	800	750	1125
	SD75S1050 6BCD	710	1000	1050	630	900	840	1260
	SD75S1200 6BCD	900	1200	1200	710	1000	950	1425
	SD75S1400 6BCD	1000	1400	1400	900	1200	1140	1710
	SD75S1550 6BCD	1100	1500	1550	1000	1400	1270	1905
	SD75S1750 6BCD	1250	1700	1750	1100	1500	1420	2130
	SD75S1850 6BCD	1400	1800	1850	1250	1700	1500	2250
	SD75S2200 6BCD	1600	2100	2200	1400	1800	1800	2700
	SD75S2500 6BCD	1800	2400	2500	1600	2100	2000	3000

POWER RANGE AT 525VAC

FRAME	CODE	Operation temperature 40°C			Operation temperature 50°C			OVERLOAD (A)
		NORMAL DUTY			HEAVY DUTY			
		Motor power (kW)	Motor power (hp)	I(A) Rated	Motor power (kW)	Motor power (hp)	I(A) Rated	
4 [1]	SD75S0055 6BCD	45	60	55	37	50	42	63
	SD75S0065 6BCD	55	75	65	45	60	52	78
	SD75S0075 6BCD	60	90	75	55	75	62	93
	SD75S0100 6BCD	90	125	100	60	90	80	120
	SD75S0120 6BCD	110	150	120	90	125	105	157
5	SD75S0160 6BCD	132	180	160	110	150	130	195
	SD75S0180 6BCD	150	200	180	132	180	150	225
	SD75S0210 6BCD	180	250	210	150	200	170	255
6	SD75S0250 6BCD	220	300	250	180	250	210	315
	SD75S0310 6BCD	250	350	310	220	300	260	390
7	SD75S0400 6BCD	355	450	400	250	350	320	480
	SD75S0480 6BCD	400	550	480	355	450	385	578
8	SD75S0570 6BCD	500	650	570	400	550	460	690
	SD75S0680 6BCD	560	800	680	500	650	550	825
>8	SD75S0825 6BCD	710	950	825	560	800	660	990
	SD75S0930 6BCD	800	1100	930	710	950	750	1125
	SD75S1050 6BCD	900	1250	1050	800	1100	840	1260
	SD75S1200 6BCD	1000	1400	1200	900	1250	950	1425
	SD75S1400 6BCD	1200	1600	1400	1000	1400	1140	1710
	SD75S1550 6BCD	1300	1700	1550	1200	1600	1270	1905
	SD75S1750 6BCD	1500	2000	1750	1300	1700	1420	2130
	SD75S1850 6BCD	1600	2200	1850	1500	2000	1500	2250
	SD75S2200 6BCD	1900	2500	2200	1600	2200	1800	2700
	SD75S2500 6BCD	2200	2900	2500	1900	2500	2000	3000

POWER RANGE AT 600VAC

FRAME	CODE	Operation temperature 40°C			Operation temperature 50°C			OVERLOAD (A)
		NORMAL DUTY			HEAVY DUTY			
		Motor power (kW)	Motor power (hp)	I(A) Rated	Motor power (kW)	Motor power (hp)	I(A) Rated	
4 [1]	SD75S0055 6BCD	45	60	55	37	50	42	63
	SD75S0065 6BCD	55	75	65	45	60	52	78
	SD75S0075 6BCD	75	100	75	55	75	62	93
	SD75S0100 6BCD	90	125	100	75	100	80	120
	SD75S0120 6BCD	110	150	120	90	125	105	157
5	SD75S0160 6BCD	132	200	160	110	150	130	195
	SD75S0180 6BCD	160	250	180	132	200	150	225
	SD75S0210 6BCD	200	300	210	160	250	170	255
6	SD75S0250 6BCD	250	350	250	200	300	210	315
	SD75S0310 6BCD	315	400	310	250	350	260	390
7	SD75S0400 6BCD	355	450	400	315	400	320	480
	SD75S0480 6BCD	450	600	480	355	450	385	578
8	SD75S0570 6BCD	560	700	570	450	600	460	690
	SD75S0680 6BCD	630	900	680	560	700	550	825
>8	SD75S0825 6BCD	800	1000	825	630	900	660	990
	SD75S0930 6BCD	900	1200	930	800	1000	750	1125
	SD75S1050 6BCD	1000	1400	1050	900	1200	840	1260
	SD75S1200 6BCD	1200	1600	1200	1000	1400	950	1425
	SD75S1400 6BCD	1400	1800	1400	1200	1600	1140	1710
	SD75S1550 6BCD	1500	2000	1550	1400	1800	1270	1905
	SD75S1750 6BCD	1700	2200	1750	1500	2000	1420	2130
	SD75S1850 6BCD	1800	2400	1850	1700	2200	1500	2250
	SD75S2200 6BCD	2100	2750	2200	1800	2400	1800	2700
	SD75S2500 6BCD	2200	3000	2500	2100	2750	2000	3000

POWER RANGE AT 690VAC

DIMENSIONS AND WEIGHTS

FRAME	W	D	H	WEIGHT (kg)
1	190	273	507	15
2	296	323	510	26
3	301	358	854	67.5
4	320	466	1249	94
5	431	529	1716	200
6	780	529	1715	335
7	1132	529	1715	479
8	1482	529	1715	585

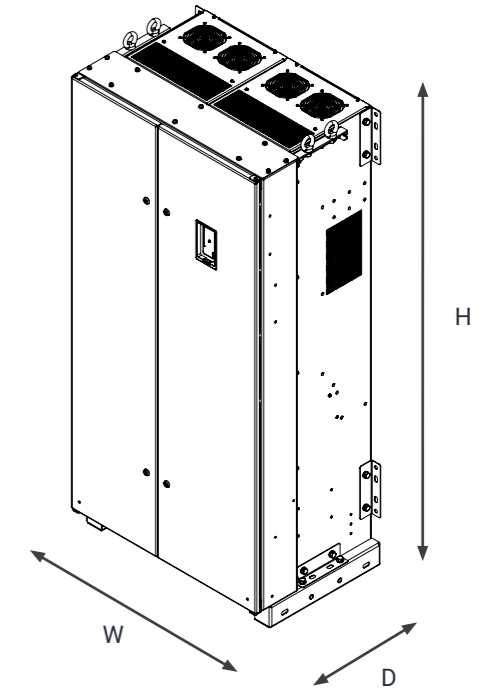

FRAMES 1 TO 8

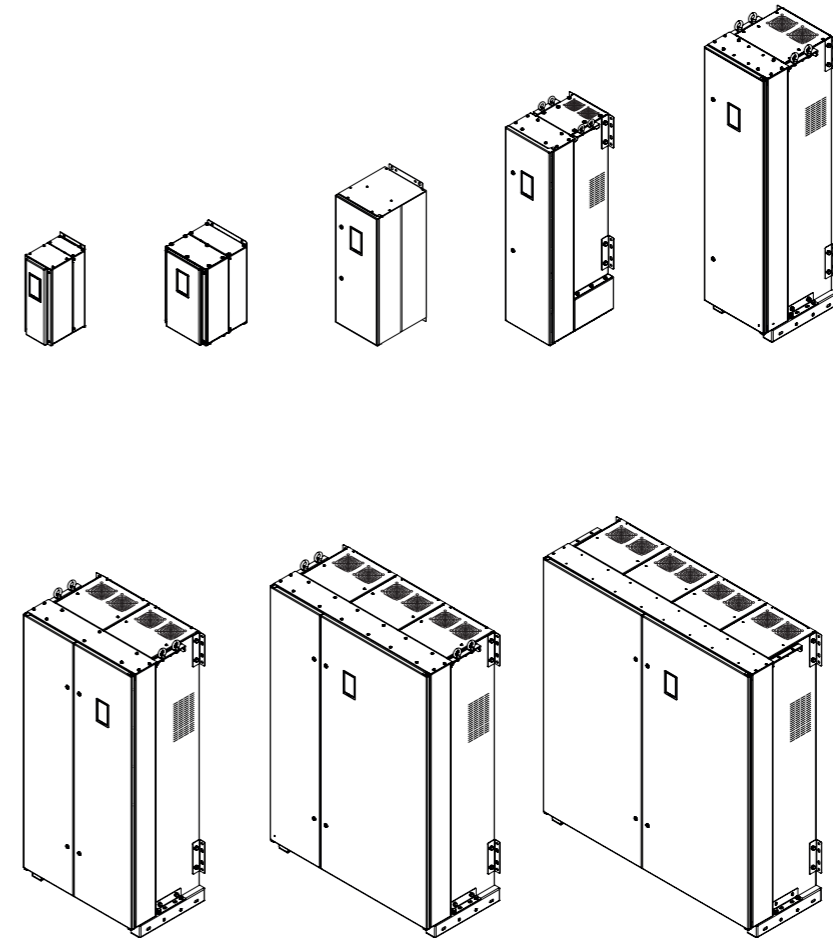

SD750SP

Reduce your levelized cost of water.

For energy applications the SD750SP ensures your investment on new and retrofit projects.



1,5kW to 1000kW



540 Vdc
to 1000 Vdc



Up to 50°C



SD750SP Series goes one step ahead keeping the family unique characteristics.

1 Solar Pumping

Power Electronics has a strong commitment to reduce the levelized cost of water (LCoW) by offering upgraded energy saving solutions. Synergies between our Industrial and Solar Divisions have come together in the SD750SP SOLAR POWER – SD750SP.

2 Solar Assisted

SD750SP is connected simultaneously to the mains (AC) and PV field (DC). The AC input voltage determines the SD750SP DC bus voltage and therefore the required DC voltage of the strings. The maximum energy produced at the fixed DC voltage depends on the number of PV panels connected in series.

3 Self-Sufficient Operation

The SD750SP is only connected to the PV field, generating the necessary power to start and speed-up the pump. The minimum power required depends on the hydraulic response of the complete pump-load system.

The SD750SP is a customized SD750 VSD with increased DC range, adapted to work with AC or DC or hybrid supply. The SD750SP has an upgraded firmware also able to find the MPP to maximize the performance running in solar mode.

Optionally Solar Kits with Diode, DC-protections, disconnection and filtering are available. Our engineering and consulting department will support you with PV sizing and SD750SP selection. A fully integration in a cabinet is also ready to which leads to easy installation and commissioning.

SD750SP

INPUT	POWER RANGE ^[1]	1.5kW – 1000kW	
	VOLTAGE RANGE AC	380 – 480 Vac ($\pm 10\%$),	
	VOLTAGE RANGE DC	540 – 1000Vdc (Frames 1 and 2 up to 830Vdc)	
	INPUT FREQUENCY	50Hz/60Hz ($\pm 6\%$)	
	INPUT RECTIFIER TECHNOLOGY	Diode-Diode Frames 1 and 2 / Thyristor-Diode Frames 3 to 8	
	DISPLACEMENT POWER FACTOR (DPF = $\cos \Phi$)	≥ 0.98	
	POWER FACTOR (PF= $I_1/I_{rms} \cdot \cos \Phi$)	≥ 0.91	
	MOMENTARY POWER LOSS	> 2s (depending on the load inertia)	
	EMC INPUT FILTER	Second environment (Industrial): (C3 Standard) First environment (Domestic): C2 (Optional). C1 consult Power Electronics Optional IT filter	
	HARMONICS FILTER	Choke coils 3% impedance	
	CURRENT THD (%)	< 40%	
	REGENERATIVE	NO	
	OUTPUT	OUTPUT FREQUENCY ^[2]	0...599Hz
		OVERLOAD CAPACITY	Constant torque: 125% during 30s at 50°C
	EFFICIENCY (At full load)	$\geq 98\%$	
	CONTROL METHOD	V/Hz VECTOR CONTROL Open Loop. PWM speed control / torque, AVC: speed control / torque Close Loop (Encoder): PWM speed control / torque, AVC: speed control / torque PMSM I/f, sensorless and HEPOL (High Efficiency Performance Open Loop)	
	CARRIER FREQUENCY	4 to 8kHz – PEWave	
	OUTPUT DV/DT FILTER	500 to 800V/ μ s	
	OUTPUT CABLE LENGTH ^[3]	USC 300m, SC 150m	
	DYNAMIC BRAKE	External B150 Dynamic Brake (Integrated in Frames 1 and 2)	
ENVIRONMENTAL RATINGS	OPERATION AMBIENT TEMPERATURE	Minimum: -20°C Maximum: +50°C	
	STORAGE TEMPERATURE	Minimum: -40°C Maximum: +70°C	
	ALTITUDE	1000m	
	POWER ALTITUDE DERATING ^[1]	> 1000m, 1% PN(kW) per 100m; 4000m maximum	
	AMBIENT HUMIDITY	<95%, non-condensing	
	DEGREE OF PROTECTION	IP20 ^[4] , IP54 ^[5] , IP42 ^[6]	
	VIBRATION	Amplitude: ± 1 mm (2Hz-13.2Hz), ± 0.075 mm (13.2Hz-57Hz) Acceleration: 6.86m/s ² (13.2Hz-57Hz), 9.8m/s ² (57Hz-150Hz)	
	HEATING RESISTORS	Optional	
PROTECTIONS	MOTOR PROTECTIONS	Rotor Locked, Motor overload (thermal model), Output current limit, Phase current imbalance, Phase voltage imbalance, Motor overtemperature (PT100 signal), Speed Limit, Torque Limit	
	DRIVE PROTECTIONS	IGBT's Overload, Input Loss, Low Input Voltage, High Input Voltage, DC Bus Voltage Limit, DC Bus Low Voltage, High Supply Frequency, Low Supply Frequency, IGBT Temperature, Heat-sink overtemperature, Power supply fault, Drive thermal model, Ground Fault, Software and Hardware fault, Analog Input signal loss (speed reference loss), Safe stop / Emergency stop	
HARDWARE	DIGITAL INPUTS	6 programmable, Active high (24Vdc). Isolated power supply	
	DIGITAL OUTPUTS	3 programmable changeover relays (250Vac, 8A or 30Vdc, 8A)	
	ANALOGUE INPUT	3 programmable differential inputs: 0 – 20mA, 4 – 20mA, 0 – 10Vdc and ± 10 Vdc, PT100 (optically isolated)	
	ANALOGUE OUTPUTS	2 isolated programmable outputs: 0 – 20mA, 4 – 20mA, 0 – 10Vdc and ± 10 Vdc	
	ENCODER INPUTS (Optional)	1 differential encoder input. Voltage inputs from 5 to 24Vdc	
	USER POWER SUPPLY	+24Vdc user power supply, (Max. 180 mA) regulated and short-circuit protected +10Vdc user power supply, (Max. 2 potentiometers R= 1 k Ω) regulated and short-circuit protected	
	I/O EXTENSION BOARD	Digital I/O board: 5 Digital Inputs: Programmable inputs and active high (24Vdc). Optically isolated. 5 Digital Outputs: programmable multi-function relays. Analogue I/O board: 2 Analogue Inputs: Programmable and differential input. 2 Analogue Outputs: Programmable outputs in voltage / current.	
	EXTERNAL POWER SUPPLY	24Vdc External Power Supply	
	SD CARD	Port for an external SD Card. Data Logging, events registration	

COMMUNICATION	STANDARD HARDWARE	USB port RS485 port Ethernet	
	OPTIONAL HARDWARE	Optical fiber Communication Cards	
	STANDARD PROTOCOL	Modbus-RTU Ethernet (Modbus TCP)	
	OPTIONAL PROTOCOL	Profibus-DP Ethernet IP ProfiNet	
CONTROL PANEL	TYPE	Removable	
	LENGTH	3 meters and 5 meters (optional)	
	CONNECTION	USB	
	VISUALIZATION LEDS	LED RUN: Motor receiving power supply LED FAULT: Flashing displays that a fault has occurred	
	LCD DISPLAY	LCD screen Keypad with 68 keys to control and configure the drive, start and stop / reset Independent memory Wi-Fi communication module (optional)	
	DISPLAY INFORMATION	Average current and 3-phase motor current Average voltage and 3-phase motor voltage Average input voltage and 3-phase input voltage 3-phase motor input and output frequency DC Bus Voltage	
	OTHERS	Drive Status Speed, Torque, Power, Power Factor of the motor Register of total and partial drive running time with reset function (hours) Register of total and partial drive energy consumption with reset function (kWh) Relay status Digital inputs / PTC status Output comparator status Analogue inputs and sensor values Analogue outputs value Motor and equipment overload status IGBT and rectifier temperature Fault history (last 6 faults) Real time clock Perpetual calendar	
	REGULATIONS	CERTIFICATIONS	CE, cTick, UL ^[7] , cUL ^[7]
		ELECTROMAGNETIC COMPATIBILITY	EMC Directive (2004/108/CE) IEC/EN 61800-3
		DESIGN AND CONSTRUCTION	LVD Directive (2006/95/CE) IEC/EN 61800-2 General requirements IEC/EN 61800-5-1 Safety IEC/EN 60146-1-1 Semiconductors
FUNCTIONAL SAFETY		IEC 60068-2-6 – Vibration IEC/EN 61800-5-2 Safety Stop (STO)	

NOTES

[1]: For operation frequencies higher than 100Hz consult Power Electronics.
[2]: Valid for frames 3 to 11, depending on the SD750 rated power. Optional filter available for frames 1 and 2.
[3]: SC: Shielded cable, USC: Unshielded Cable. Follow Power Electronics installation recommendations. For greater cable lengths, consult Power Electronics.

[4] Available for 380–480Vac up to frame 4.
[5] Applicable to the electronics.
[6] Applicable to the electronics.
[7] In certification process.

SD750SP CONFIGURATION TABLE

SD750 SERIES		ND OUTPUT CURRENT		A INPUT VOLTAGE		B DEGREE OF PROTECTION		C GROUNDING CONNECTION		D > 4000 METER (above sea level)	
SD750P	SD750 SP	0006	3 A	5	380-480 Vac	2	IP20	S	TT/TN	S	Not needed
				5	IP54	T	IT	A	Needed
		1800	1800 A			4	IP42				

SD750SP STANDARD RATINGS

FRAME	CODE	"Operating Temperature 50 °C AC POWER"			"Operating Temperature 50 °C DC POWER"	
		I (A) Nominal	Power (kW) 400 VCA	150% Overloading (A) 60s	Input I(A) DC	Input I(A) DC 125% Overloading 30s
1	SD75P0006 5BCD	6	2,2	9	6	8
	SD75P0009 5BCD	9	4	14	9	11
	SD75P0012 5BCD	12	5,5	18	12	15
	SD75P0018 5BCD	18	7,5	27	18	23
	SD75P0024 5BCD	24	11	36	24	30
2	SD75P0032 5BCD	32	15	48	32	40
	SD75P0038 5BCD	38	18,5	57	38	48
	SD75P0048 5BCD	48	22	72	48	60
3	SD75P0060 5BCD	60	30	90	60	75
	SD75P0075 5BCD	75	37	113	75	94
	SD75P0090 5BCD	90	45	135	90	113
	SD75P0115 5BCD	115	55	173	115	144
4	SD75P0150 5BCD	150	75	225	150	188
	SD75P0170 5BCD	170	90	255	170	213
5	SD75P0210 5BCD	210	110	315	210	263
	SD75P0250 5BCD	250	132	375	250	313
	SD75P0275 5BCD	275	150	413	275	344
6	SD75P0330 5BCD	330	160	495	330	413
	SD75P0370 5BCD	370	220	555	370	463
	SD75P0460 5BCD	460	250	690	460	575
7	SD75P0580 5BCD	580	315	870	580	725
	SD75P0650 5BCD	650	355	975	650	813
	SD75P0720 5BCD	720	400	1080	720	900
8	SD75P0840 5BCD	840	450	1260	840	1050
	SD75P0925 5BCD	925	500	1388	925	1156
	SD75P0990 5BCD	990	560	1485	990	1238
>8	SD75P1150 5BCD	1150	630	1725	1150	1438
	SD75P1260 5BCD	1260	710	1890	1260	1575
	SD75P1440 5BCD	1440	800	2160	1440	1800
	SD75P1580 5BCD	1580	900	2370	1580	1975
	SD75P1800 5BCD	1800	1000	2700	1800	2250

400 Vca - 565Vcc

DIMENSIONS AND WEIGHTS

FRAME	W	D	H	WEIGHT (kg)
1	190	273	507	15
2	296	323	510	26
3	301	358	854	67.5
4	320	466	1249	94
5	431	529	1716	200
6	780	529	1715	335
7	1132	529	1715	479
8	1482	529	1715	585

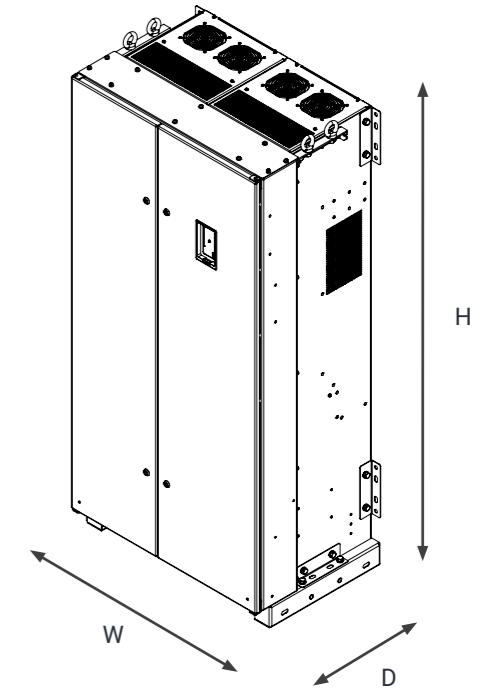

FRAMES 1 TO 8

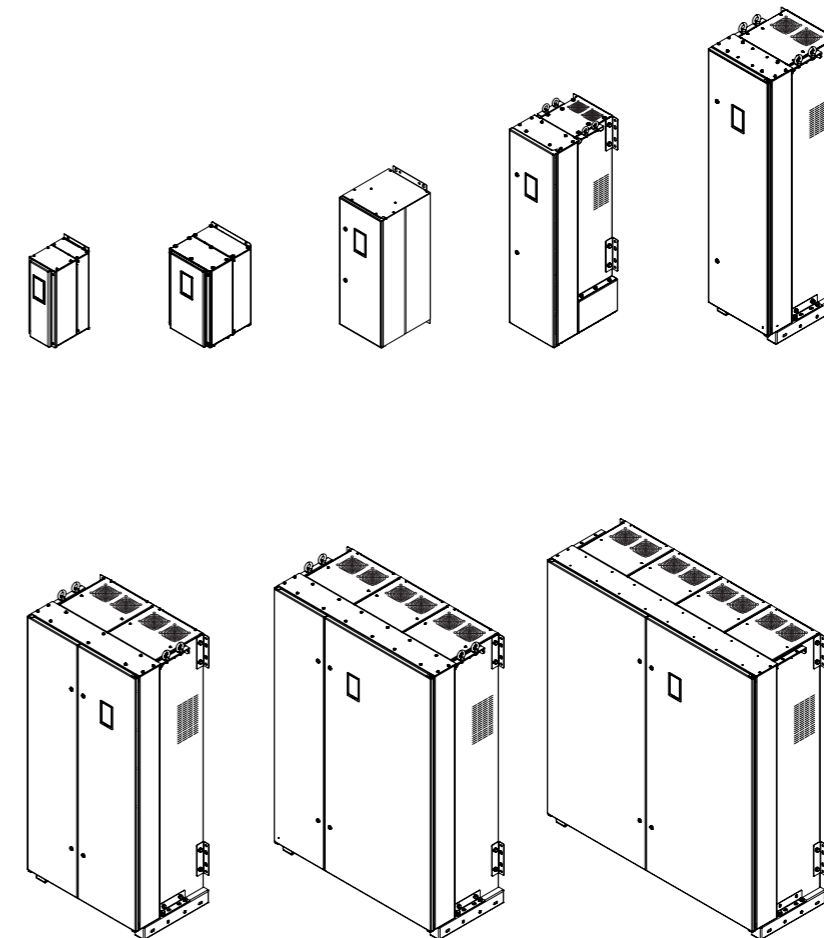

SD750FR

Reduce your energy bills
and increase the process
performance at the same time.



110kW - 2200kW



380-480Vac
690 Vac



Up to 50°C

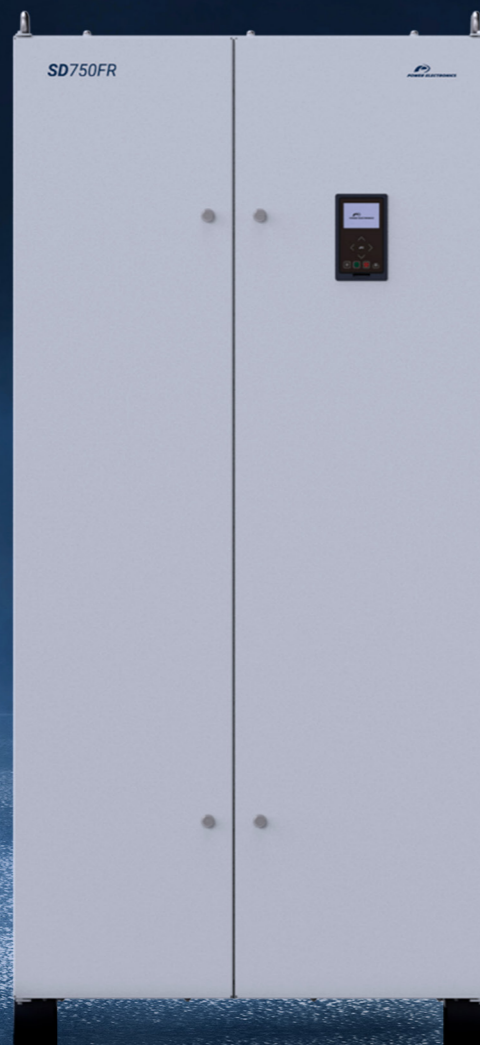

SD750FR Series
goes one step ahead
keeping the family
unique characteristics.

1 Active Front
End Technology

2 Energy Regeneration
4 quadrand operation

3 Low Harmonics
THDI <5%

Based on the latest Active Front End technology, they are able to:
regenerate the braking energy, reduce the THDi<5%^[1], adjust the cosine
phi and keep it constant at any load condition, and keep the motor
voltage constant even when high input voltage drops occur.

SD750FR

INPUT	Power range ^[1]	110kW – 2200kW	
	Voltage range	380 - 480Vac (±10%), 690 (-5/+10%)	
	Input frequency	50Hz/60Hz (±6%)	
	Input rectifier technology	IGBT	
	Restifier bridge switching frequency	2.8kHz	
	Displacement power factor (DPF = cos φ)	1 (factory settings) 0.90 leading ... 0.90 lagging (adjustable)	
	Power factor (PF= i1/irms · cos φ)	≥ 0.98	
	Momentary power loss	> 2sec (depending on the load inertia)	
	EMC input filter	Second environment (Industrial): C3 Standard. First environment (Domestic): C2 (Optional), C1 consult with Power Electronics.	
	Harmonics filter	LCL	
	Current thd (%)	< 3% / 5% ^[2]	
	Regenerative	Yes – 4 quadrant operation	
	OUTPUT	Output frequency ^[3]	0... 599Hz
		Overload capacity	Constant torque/heavy duty: 150% during 60 sec at 50°C Variable torque/normal duty: 120% during 60 sec at 40°C.
Efficiency (at full load)		≥97%	
Control method		V/Hz	VECTOR CONTROL
		Open Loop: PMC speed / torque control, AVC: speed / torque control	
		Close Loop (Encoder): PMC speed / torque control, AVC: speed / torque control PMSM I/f, Sensorless and HEPOL (High Efficiency Performance Open Loop)	
Carrier frequency		4 to 8kHz – PEWave	
Output dV/dt filter		500 - 800 V/μs ^[3]	
Output cable length ^[4]		USC 300m, SC 150m	
Dynamic brake		-	
ENVIRONMENTAL CONDITIONS	Operation ambient temperature	Minimum: -20°C; Maximum: +50°C (Heavy Duty) Minimum: -20°C; Maximum: +40°C (Normal Duty)	
	Storage temperature	Minimum: -40°C; Maximum: +70°C	
	Altitude	1000m	
	Power altitude derating ^[1]	>1000m, 1% PN (kW) per 100m; 4000m maximum (for higher altitude consult with PE)	
	Ambient humidity	<95%, non-condensing	
	Degree of protection	IP54 ^[5] , IP42 ^[6] , Marine series adapted (IP44/IP54, under request)	
	Vibration	Amplitude: ± 1mm (2Hz-13.2Hz), ± 0.075mm (13.2Hz-57Hz) Acceleration: 6.86m/s ² (13.2Hz-57Hz), 9.8m/s ² (57Hz-150Hz)	
	Heating resistors	Optional	
PROTECTIONS	Motor protections	Rotor locked, Motor overload (thermal model), Output current limit, Phase current imbalance, Phase voltage imbalance, Motor over-temperature (PT100 signal), Speed limit Torque limit.	
	Drive protections	IGBT's overload, Input phase loss, Low input voltage, High input voltage, DC Bus voltage limit, Low DC Bus voltage, High input frequency, Low input frequency, IGBT temperature, Heat-sink over-temperature, Power supply fault, Drive thermal model, Ground fault, Software and Hardware fault, Analogue input signal loss (speed reference loss), Safe stop/Emergency Stop	

HARDWARE	Digital inputs	6 programmable, Active high (24Vdc), Isolated power supply	
	Digital outputs	3 programmable changeover relays (250Vac, 8A or 30Vdc, 8A)	
	Analogue input	3 programmable differential inputs. 0 – 20mA, 4 – 20mA, 0 – 10Vdc and ±10Vdc, PT100. (Optically isolated)	
	Analogue outputs	Two isolated programmable outputs: 0 – 20mA, 4 – 20mA, 0 – 10Vdc and ±10Vdc	
	Encoder inputs (optional)	One differential encoders input. Voltages inputs from 5 to 24Vdc	
	User power supply	+24Vdc user power supply (Max 180mA) regulated and short-circuit protected +10Vdc user power supply (Max 2 potentiometers R= 1 kΩ) regulated and short-circuit	
	I/O Extension board (optional)	Digital I/O board:	5 Digital Inputs: Programmable inputs and active high (24Vdc). Optically isolated. 5 Digital Outputs: programmable multi-function relays.
		Analogue I/O board:	2 Analogue Input: Programmable and differential input. 2 Analogue Output: Programmable outputs in voltage / current.
	External power supply (optional)	24 V External Power Supply integrated	
	SD card	Port for an external SD Card. Data Logging, events registration.	
COMMUNICATIONS	Standard hardware	USB port RS485 port Ethernet	
	Optional hardware	Optical fiber Communication boards	
	Standard protocol	Modbus-RTU Ethernet (Modbus TCP)	
	Optional protocol	Profibus-DP Ethernet IP ProfiNet	
CONTROL PANEL	Type	Removable	
	Length	3 meters (optional)	
	Connection	USB	
	Visualization leds	LED RUN: Motor receiving power supply LED FAULT: Flashing displays that a fault has occurred	
	LCD display	LCD Screen Keypad with 8 keys to control and configure the drive, start and stop/reset Independent memory	
	Display information	Average current and 3-phase motor current Average voltage and 3-phase motor voltage Average input voltage and 3-phase input voltage 3-phase input and output frequency DC Bus Voltage Drive Status	
		Real time clock Perpetual calendar Speed, Torque, Power, Power factor of motor Register of total and partial drive running time with reset function. (hours) Register of total and partial drive energy consumption with reset function (kWh)	
		Relay status	
	Others	Digital inputs / PTC status	
		Output comparator status	
Analogue inputs and sensor values			
Analogue output value			
Motor overload and equipment status Drive and rectifier temperature Fault history (last 6 faults)			
REGULATIONS	Certifications	CE, cTick, UL ^[7] , cUL ^[7] , Marine certifications (under request)	
	Electromagnetic compatibility	EMC Directive (2004/108/CE) IEC/EN 61800-3	
		LVD Directive (2006/95/CE) IEC/EN 61800-2 General requirements	
	Design and construction	IEC/EN 61800-5-1 Safety IEC/EN 60146-1-1 Semiconductor converters IEC60068-2-6 – Vibration	
	Functional safety	IEC/EN 61800-5-2 Safety Stop (STO)	

[1]: Consult with Power Electronics for other configurations.
[2]: THDi < 3% (THDv = 0%). Harmonics are below the limits defined in IEEE519 for all Isc / IL.
[3]: For operation frequencies higher than 100Hz consult Power Electronics.

[4]: SC: Shielded cable, USC: Unshielded Cable. Follow Power Electronics installation recommendations. For greater cable lengths, consult Power Electronics.
[5]: Applicable to the electronics.
[6]: For stand-alone models.
[7]: Certification in process.

SD750FR CONFIGURATION TABLE

SD750 SERIES		ND OUTPUT CURRENT		A INPUT VOLTAGE		B DEGREE OF PROTECTION		C GROUNDING CONNECTION		D > 4000 METER (above sea level)	
SD750F	SD750FR	0130	130A	5	380-480	5	IP54	S	TT/TN	S	Not needed
		6	690	4	IP42	T	IT	A	Needed
		3100	3100A								

SD750FR STANDARD RATINGS

FRAME	CODE	Operation temperature 40°C			Operation temperature 50°C			OVERLOAD (A)
		NORMAL DUTY			HEAVY DUTY			
		Motor power (kW)	Motor power (hp)	I(A) Rated	Motor power (kW)	Motor power (hp)	I(A) Rated	
5	SD75F0260 5BCD	132	200	260	110	150	210	315
	SD75F0320 5BCD	160	250	320	132	200	250	375
	SD75F0340 5BCD	200	270	340	150	220	275	413
6	SD75F0400 5BCD	220	300	400	160	250	330	495
	SD75F0450 5BCD	250	350	450	220	300	370	555
	SD75F0570 5BCD	315	400	570	250	350	460	690
7	SD75F0700 5BCD	400	550	700	315	450	580	870
	SD75F0800 5BCD	450	650	800	355	500	650	975
	SD75F0900 5BCD	500	700	900	400	550	720	1080
8	SD75F1050 5BCD	560	800	1050	450	700	840	1260
	SD75F1140 5BCD	630	900	1140	500	750	925	1388
	SD75F1230 5BCD	710	940	1230	560	800	990	1485
>8	SD75F1400 5BCD	800	1000	1400	630	900	1150	1725
	SD75F1550 5BCD	900	1250	1550	710	1000	1260	1890
	SD75F1800 5BCD	1000	1400	1800	800	1150	1440	2160
	SD75F1950 5BCD	1100	1500	1950	900	1250	1580	2370
	SD75F2250 5BCD	1200	1750	2250	1000	1450	1800	2700
	SD75F2750 5BCD	1500	2200	2750	1200	1750	2200	3300
	SD75F3100 5BCD	1750	2450	3100	1400	2000	2500	3750

FRAME	CODE	Operation temperature 40°C			Operation temperature 50°C			OVERLOAD (A)
		NORMAL DUTY			HEAVY DUTY			
		Motor power (kW)	Motor power (hp)	I(A) Rated	Motor power (kW)	Motor power (hp)	I(A) Rated	
5	SD75F0260 5BCD	132	200	236	110	150	191	286
	SD75F0320 5BCD	160	250	291	132	200	227	341
	SD75F0340 5BCD	200	270	309	150	220	250	375
6	SD75F0400 5BCD	220	300	364	160	250	300	450
	SD75F0450 5BCD	250	350	409	220	300	336	505
	SD75F0570 5BCD	315	400	518	250	350	418	627
7	SD75F0700 5BCD	400	550	636	315	450	527	791
	SD75F0800 5BCD	450	650	727	355	500	591	886
	SD75F0900 5BCD	500	700	818	400	550	655	982
8	SD75F1050 5BCD	560	800	955	450	700	764	1145
	SD75F1140 5BCD	630	900	1036	500	750	841	1262
	SD75F1230 5BCD	710	940	1118	560	800	900	1350
>8	SD75F1400 5BCD	800	1000	1273	630	900	1045	1568
	SD75F1550 5BCD	900	1250	1409	710	1000	1145	1718
	SD75F1800 5BCD	1000	1400	1636	800	1150	1309	1964
	SD75F1950 5BCD	1100	1500	1773	900	1250	1436	2155
	SD75F2250 5BCD	1200	1750	2045	1000	1450	1636	2455
	SD75F2750 5BCD	1500	2200	2500	1200	1750	2000	3000
	SD75F3100 5BCD	1750	2450	2818	1400	2000	2273	3409

FRAME	CODE	Operation temperature 40°C			Operation temperature 50°C			OVERLOAD (A)
		NORMAL DUTY			HEAVY DUTY			
		Motor power (kW)	Motor power (hp)	I(A) Rated	Motor power (kW)	Motor power (hp)	I(A) Rated	
5	SD75F0260 5BCD	132	200	217	110	150	175	263
	SD75F0320 5BCD	160	250	267	132	200	208	313
	SD75F0340 5BCD	200	270	283	150	220	229	344
6	SD75F0400 5BCD	220	300	333	160	250	275	413
	SD75F0450 5BCD	250	350	375	220	300	308	463
	SD75F0570 5BCD	315	400	475	250	350	383	575
7	SD75F0700 5BCD	400	550	583	315	450	483	725
	SD75F0800 5BCD	450	650	667	355	500	542	813
	SD75F0900 5BCD	500	700	750	400	550	600	900
8	SD75F1050 5BCD	560	800	875	450	700	700	1050
	SD75F1140 5BCD	630	900	950	500	750	771	1157
	SD75F1230 5BCD	710	940	1025	560	800	825	1238
>8	SD75F1400 5BCD	800	1000	1167	630	900	958	1438
	SD75F1550 5BCD	900	1250	1292	710	1000	1050	1575
	SD75F1800 5BCD	1000	1400	1500	800	1150	1200	1800
	SD75F1950 5BCD	1100	1500	1625	900	1250	1317	1975
	SD75F2250 5BCD	1200	1750	1875	1000	1450	1500	2250
	SD75F2750 5BCD	1500	2200	2292	1200	1750	1833	2750
	SD75F3100 5BCD	1750	2450	2583	1400	2000	2083	3125

FRAME	CODE	Operation temperature 40°C			Operation temperature 50°C			OVERLOAD (A)
		NORMAL DUTY			HEAVY DUTY			
		Motor power (kW)	Motor power (hp)	I(A) Rated	Motor power (kW)	Motor power (hp)	I(A) Rated	
5	SD75F0160 6BCD	132	200	160	110	150	130	195
	SD75F0180 6BCD	160	250	180	132	200	150	225
	SD75F0210 6BCD	200	300	210	160	250	170	255
6	SD75F0250 6BCD	250	350	250	200	300	210	315
	SD75F0310 6BCD	315	400	310	250	350	260	390
	SD75F0400 6BCD	355	450	400	315	400	320	480
7	SD75F0480 6BCD	450	600	480	355	450	385	578
	SD75F0570 6BCD	560	700	570	450	600	460	690
8	SD75F0680 6BCD	630	900	680	560	700	550	825
	SD75F0825 6BCD	800	1000	825	630	900	660	990
	SD75F0930 6BCD	900	1200	930	800	1000	750	1125
>8	SD75F1050 6BCD	1000	1400	1050	900	1200	840	1260
	SD75F1200 6BCD	1200	1600	1200	1000	1400	950	1425
	SD75F1400 6BCD	1400	1800	1400	1200	1600	1140	1710
	SD75F1550 6BCD	1500	2000	1550	1400	1800	1270	1905
	SD75F1750 6BCD	1700	2200	1750	1500	2000	1420	2130
	SD75F1850 6BCD	1800	2400	1850	1700	2200	1500	2250
	SD75F2200 6BCD	2100	2750	2200	1800	2400	1800	2700
	SD75F2500 6BCD	2200	3000	2500	2100	2750	2000	3000

DIMENSIONS AND WEIGHTS

FRAME	W	D	H	WEIGHT (kg)
5	595	730	2000	350
6	945	730	2000	700
7	1295	730	2000	1000
8	1645	730	2000	1200

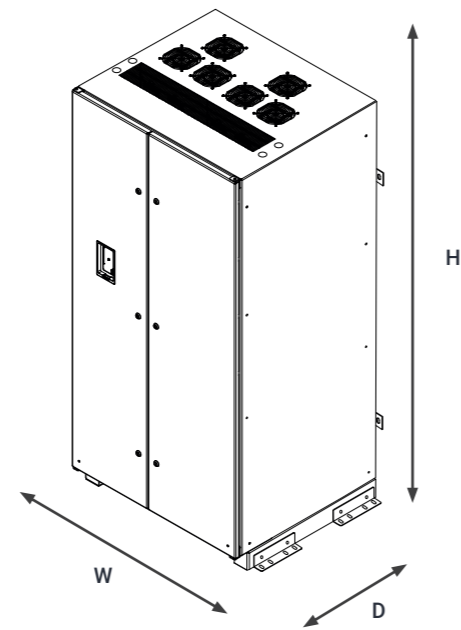

FRAMES 5 TO 8

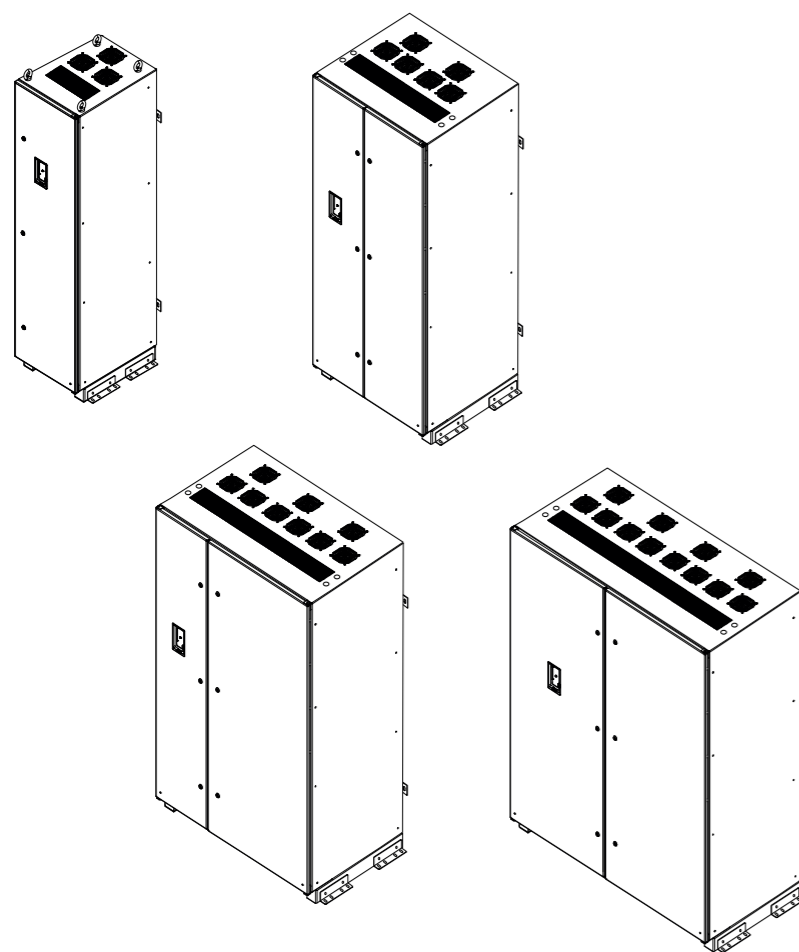

SD750K

Keeps the advanced family features reducing up to 2.5 times the size.



110kW - 2200kW



380-480Vac
525 Vac
690 Vac



Up to 50°C



SD750K Series goes one step ahead keeping the family unique characteristics.

1 Space Saving

When the space saving is the must, the SD750 Kompakt series with a power density up to 2200kW is your suitable solution.

2 IP00 and IP20 option

Inspired by the contactors wiring concept, it has a top input power and a bottom output motor cable. The drive unit and the input chokes are delivered together with a IP00 degree of protection.

3 Built-In dv/dt Filter

Inspired by the contactors wiring concept, it has a top input power and a bottom output motor cable. The drive unit and the input chokes are delivered together with a IP00 degree of protection.

SD750K

INPUT	Power range ^[1]	110kW - 2200kW	
	Voltage range	380 - 480Vac (10%), 525 (-5/+10%), 600 - 690 (-5/+10%)	
	Input frequency	50Hz/60Hz (±6%)	
	Input rectifier technology	Diode-Diode F1-F2/Thyristor-Diode F3-F11 (multipulse available ^[1])	
	Displacement power factor (DPF = cos Φ)	≥ 0.98	
	Power factor (PF= i1/irms · cos φ)	≥ 0.91	
	Momentary power loss	> 2sec (depending on the load inertia)	
	EMC input filter	Second environment (Industrial): C3 Standard. First environment (Domestic): C2 (Optional), C1 consult with Power Electronics. IT filter optional	
	Harmonics filter	LCL	
	Current thd (%)	<40%	
	Regenerative	No	
	OUTPUT	Output frequency ^[2]	0... 599Hz
		Overload capacity	Constant torque/heavy duty: 150% during 60 sec at 50°C Variable torque/normal duty: 120% during 60 sec at 40°C.
Efficiency (at full load)		≥98%	
Control method		V/Hz VECTOR CONTROL Open Loop: PMC speed / torque control, AVC: speed / torque control Close Loop (Encoder): PMC speed / torque control, AVC: speed / torque control PMSM I/f, Sensorless and HEPOL (High Efficiency Performance Open Loop)	
Carrier frequency		4 to 8kHz – PEWave	
Output dV/dt filter		500 - 800 V/μs	
Output cable length ^[3]		USC 300m, SC 150m	
Dynamic brake		External B150 Dynamic Brake (Frames 1 and 2 integrated)	
ENVIRONMENTAL CONDITIONS		Operation ambient temperature	Minimum: -20°C; Maximum: +50°C (Heavy Duty) Minimum: -20°C; Maximum: +40°C (Normal Duty)
		Storage temperature	Minimum: -40°C; Maximum: +70°C
	Altitude	1000m	
	Power altitude derating ^[1]	>1000m, 1% PN (kW) per 100m; 4000m maximum (for higher altitude consult with PE)	
	Ambient humidity	<95%, non-condensing	
	Degree of protection	IP00 ^[5] , IP20 ^[6] , Marine series adapted (IP44/IP54, under request)	
	Vibration	Amplitude: ± 1mm (2Hz-13.2Hz), ± 0.075mm (13.2Hz-57Hz) Acceleration: 6.86m/s ² (13.2Hz-57Hz), 9.8m/s ² (57Hz-150Hz)	
PROTECTIONS	Heating resistors	Optional	
	Motor protections	Rotor locked, Motor overload (thermal model), Output current limit, Phase current imbalance, Phase voltage imbalance, Motor over-temperature (PT100 signal), Speed limit Torque limit.	
	Drive protections	IGBT's overload, Input phase loss, Low input voltage, High input voltage, DC Bus voltage limit, Low DC Bus voltage, High input frequency, Low input frequency, IGBT temperature, Heat-sink over-temperature, Power supply fault, Drive thermal model, Ground fault, Software and Hardware fault, Analogue input signal loss (speed reference loss), Safe stop/Emergency Stop	

HARDWARE	Digital inputs	6 programmable, Active high (24Vdc), Isolated power supply	
	Digital outputs	3 programmable changeover relays (250Vac, 8A or 30Vdc, 8A)	
	Analogue input	3 programmable differential inputs. 0 – 20mA, 4 – 20mA, 0 – 10Vdc and ±10Vdc, PT100. (Optically isolated)	
	Analogue outputs	One isolated programmable outputs: 0 – 20mA, 4 – 20mA, 0 – 10Vdc and ±10Vdc	
	Encoder inputs (optional)	Two differential encoders input. Voltages inputs from 5 to 24Vdc	
	User power supply	+24Vdc user power supply (Max 180mA) regulated and short-circuit protected +10Vdc user power supply (Max 2 potentiometers R= 1 kΩ) regulated and short-circuit protected	
	I/O Extension board (optional)	Digital I/O board: 5 Digital Inputs: Programmable inputs and active high (24Vdc). Optically isolated. 5 Digital Outputs: programmable multi-function relays. Analogue I/O board: 2 Analogue Input: Programmable and differential input. 2 Analogue Output: Programmable outputs in voltage / current.	
	External power supply (optional)	24 V External Power Supply integrated	
	SD card	Port for an external SD Card. Data Logging, events registration.	
	COMMUNICATIONS	Standard hardware	USB port RS485 port Ethernet
Optional hardware		Optical fiber Communication boards	
Standard protocol		Modbus-RTU Ethernet (Modbus TCP)	
Optional protocol		Profibus-DP Ethernet IP ProfiNet	
CONTROL PANEL	Type	Removable	
	Length	3 meters (optional)	
	Connection	USB	
	Visualization leds	LED RUN: Motor receiving power supply LED FAULT: Flashing displays that a fault has occurred	
	LCD display	LCD Screen Keypad with 8 keys to control and configure the drive, start and stop/reset Independent memory	
	Display information	Average current and 3-phase motor current Average voltage and 3-phase motor voltage Average input voltage and 3-phase input voltage 3-phase input and output frequency DC Bus Voltage Drive Status	
	Others	Real time clock Perpetual calendar Speed, Torque, Power, Power factor of motor Register of total and partial drive running time with reset function. (hours) Register of total and partial drive energy consumption with reset function (kWh) Relay status Digital inputs / PTC status Output comparator status Analogue inputs and sensor values Analogue output value Motor overload and equipment status Drive and rectifier temperature Fault history (last 6 faults)	
	REGULATIONS	Certifications	CE, cTick, UL ^[4] , cUL ^[4] , Marine certifications (under request)
		Electromagnetic compatibility	EMC Directive (2004/108/CE) IEC/EN 61800-3
		Design and construction	LVD Directive (2006/95/CE) IEC/EN 61800-2 General requirements IEC/EN 61800-5-1 Safety IEC/EN 60146-1-1 Semiconductor converters IEC60068-2-6 – Vibration
Functional safety	IEC/EN 61800-5-2 Safety Stop (STO)		

[1]: Consult availability with Power Electronics.

[2]: For operation frequencies higher than 100Hz consult Power Electronics.

[3]: SC: Shielded cable, USC: Unshielded Cable. Follow Power Electronics installation recommendations. For greater cable lengths, consult Power Electronics.

[4]: Certification in process.

SD750K CONFIGURATION TABLE

SD750 SERIES		ND OUTPUT CURRENT		A INPUT VOLTAGE		B DEGREE OF PROTECTION		C GROUNDING CONNECTION		D > 4000 METER (above sea level)	
SD750K	SD750 Kompakt	0130	130A	5	380-480	0	IP00	S	TT/TN	S	Not needed
		6	600-690	2	IP20	T	IT	A	Needed
		3100	3100A	7	525						

SD750K STANDARD RATINGS

FRAME	CODE	Operation temperature 40°C			Operation temperature 50°C			OVERLOAD (A)
		NORMAL DUTY			HEAVY DUTY			
		Motor power (kW)	Motor power (hp)	I(A) Rated	Motor power (kW)	Motor power (hp)	I(A) Rated	
1	SD75K0260 5BCD	132	200	260	110	150	210	315
	SD75K0320 5BCD	160	250	320	132	200	250	375
	SD75K0340 5BCD	200	270	340	150	220	275	413
2	SD75K0400 5BCD	220	300	400	160	250	330	495
	SD75K0450 5BCD	250	350	450	220	300	370	555
	SD75K0570 5BCD	315	400	570	250	350	460	690
3	SD75K0700 5BCD	400	550	700	315	450	580	870
	SD75K0800 5BCD	450	650	800	355	500	650	975
	SD75K0900 5BCD	500	700	900	400	550	720	1080
4	SD75K1050 5BCD	560	800	1050	450	700	840	1260
	SD75K1140 5BCD	630	900	1140	500	750	925	1388
	SD75K1230 5BCD	710	940	1230	560	800	990	1485
>4 ^[1]	SD75K1400 5BCD	800	1000	1400	630	900	1150	1725
	SD75K1550 5BCD	900	1250	1550	710	1000	1260	1890
	SD75K1800 5BCD	1000	1400	1800	800	1150	1440	2160
	SD75K1950 5BCD	1100	1500	1950	900	1250	1580	2370
	SD75K2250 5BCD	1200	1750	2250	1000	1450	1800	2700
	SD75K2750 5BCD	1500	2200	2750	1200	1750	2200	3300
	SD75K3100 5BCD	1750	2450	3100	1400	2000	2500	3750

FRAME	CODE	Operation temperature 40°C			Operation temperature 50°C			OVERLOAD (A)
		NORMAL DUTY			HEAVY DUTY			
		Motor power (kW)	Motor power (hp)	I(A) Rated	Motor power (kW)	Motor power (hp)	I(A) Rated	
1	SD75K0260 5BCD	132	200	236	110	150	191	286
	SD75K0320 5BCD	160	250	291	132	200	227	341
	SD75K0340 5BCD	200	270	309	150	220	250	375
2	SD75K0400 5BCD	220	300	364	160	250	300	450
	SD75K0450 5BCD	250	350	409	220	300	336	505
	SD75K0570 5BCD	315	400	518	250	350	418	627
3	SD75K0700 5BCD	400	550	636	315	450	527	791
	SD75K0800 5BCD	450	650	727	355	500	591	886
	SD75K0900 5BCD	500	700	818	400	550	655	982
4	SD75K1050 5BCD	560	800	955	450	700	764	1145
	SD75K1140 5BCD	630	900	1036	500	750	841	1262
	SD75K1230 5BCD	710	940	1118	560	800	900	1350
>4 ^[1]	SD75K1400 5BCD	800	1000	1273	630	900	1045	1568
	SD75K1550 5BCD	900	1250	1409	710	1000	1145	1718
	SD75K1800 5BCD	1000	1400	1636	800	1150	1309	1964
	SD75K1950 5BCD	1100	1500	1773	900	1250	1436	2155
	SD75K2250 5BCD	1200	1750	2045	1000	1450	1636	2455
	SD75K2750 5BCD	1500	2200	2500	1200	1750	2000	3000
	SD75K3100 5BCD	1750	2450	2818	1400	2000	2273	3409

FRAME	CODE	Operation temperature 40°C			Operation temperature 50°C			OVERLOAD (A)
		NORMAL DUTY			HEAVY DUTY			
		Motor power (kW)	Motor power (hp)	I(A) Rated	Motor power (kW)	Motor power (hp)	I(A) Rated	
1	SD75K0260 5BCD	132	200	217	110	150	175	263
	SD75K0320 5BCD	160	250	267	132	200	208	313
	SD75K0340 5BCD	200	270	283	150	220	229	344
2	SD75K0400 5BCD	220	300	333	160	250	275	413
	SD75K0450 5BCD	250	350	375	220	300	308	463
	SD75K0570 5BCD	315	400	475	250	350	383	575
3	SD75K0700 5BCD	400	550	583	315	450	483	725
	SD75K0800 5BCD	450	650	667	355	500	542	813
	SD75K0900 5BCD	500	700	750	400	550	600	900
4	SD75K1050 5BCD	560	800	875	450	700	700	1050
	SD75K1140 5BCD	630	900	950	500	750	771	1157
	SD75K1230 5BCD	710	940	1025	560	800	825	1238
>4 ^[1]	SD75K1400 5BCD	800	1000	1167	630	900	958	1438
	SD75K1550 5BCD	900	1250	1292	710	1000	1050	1575
	SD75K1800 5BCD	1000	1400	1500	800	1150	1200	1800
	SD75K1950 5BCD	1100	1500	1625	900	1250	1317	1975
	SD75K2250 5BCD	1200	1750	1875	1000	1450	1500	2250
	SD75K2750 5BCD	1500	2200	2292	1200	1750	1833	2750
SD75K3100 5BCD	1750	2450	2583	1400	2000	2083	3125	

FRAME	CODE	Operation temperature 40°C			Operation temperature 50°C			OVERLOAD (A)
		NORMAL DUTY			HEAVY DUTY			
		Motor power (kW)	Motor power (hp)	I(A) Rated	Motor power (kW)	Motor power (hp)	I(A) Rated	
1	SD75K0160 7BCD	110	150	160	90	125	130	195
	SD75K0180 7BCD	132	180	180	110	150	150	225
	SD75K0210 7BCD	150	200	210	132	180	170	255
2	SD75K0250 7BCD	185	250	250	150	200	210	315
	SD75K0310 7BCD	220	300	310	185	250	260	390
	SD75K0400 7BCD	280	400	400	220	300	320	480
3	SD75K0480 7BCD	355	450	480	280	400	385	578
	SD75K0570 7BCD	400	550	570	355	450	460	690
	SD75K0680 7BCD	500	650	680	400	550	550	825
4	SD75K0825 7BCD	560	800	825	500	650	660	990
	SD75K0930 7BCD	630	900	930	560	800	750	1125
	SD75K1050 7BCD	710	1000	1050	630	900	840	1260
>4 ^[1]	SD75K1200 7BCD	900	1200	1200	710	1000	950	1425
	SD75K1400 7BCD	1000	1400	1400	900	1200	1140	1710
	SD75K1550 7BCD	1100	1500	1550	1000	1400	1270	1905
	SD75K1750 7BCD	1250	1700	1750	1100	1500	1420	2130
	SD75K1850 7BCD	1400	1800	1850	1250	1700	1500	2250
	SD75K2200 7BCD	1600	2100	2200	1400	1800	1800	2700
	SD75K2500 7BCD	1800	2400	2500	1600	2100	2000	3000

SD750K STANDARD RATINGS

FRAME	CODE	Operation temperature 40°C			Operation temperature 50°C			OVERLOAD (A)
		NORMAL DUTY			HEAVY DUTY			
		Motor power (kW)	Motor power (hp)	I(A) Rated	Motor power (kW)	Motor power (hp)	I(A) Rated	
1	SD75K0160 6BCD	132	180	160	110	150	130	195
	SD75K0180 6BCD	150	200	180	132	180	150	225
	SD75K0210 6BCD	180	250	210	150	200	170	255
2	SD75K0250 6BCD	220	300	250	180	250	210	315
	SD75K0310 6BCD	250	350	310	220	300	260	390
	SD75K0400 6BCD	355	450	400	250	350	320	480
3	SD75K0480 6BCD	400	550	480	355	450	385	578
	SD75K0570 6BCD	500	650	570	400	550	460	690
4	SD75K0680 6BCD	560	800	680	500	650	550	825
	SD75K0825 6BCD	710	950	825	560	800	660	990
>4 ^[1]	SD75K0930 6BCD	800	1100	930	710	950	750	1125
	SD75K1050 6BCD	900	1250	1050	800	1100	840	1260
	SD75K1200 6BCD	1000	1400	1200	900	1250	950	1425
	SD75K1400 6BCD	1200	1600	1400	1000	1400	1140	1710
	SD75K1550 6BCD	1300	1700	1550	1200	1600	1270	1905
	SD75K1750 6BCD	1500	2000	1750	1300	1700	1420	2130
	SD75K1850 6BCD	1600	2200	1850	1500	2000	1500	2250
	SD75K2200 6BCD	1900	2500	2200	1600	2200	1800	2700
	SD75K2500 6BCD	2200	2900	2500	1900	2500	2000	3000

FRAME	CODE	Operation temperature 40°C			Operation temperature 50°C			OVERLOAD (A)
		NORMAL DUTY			HEAVY DUTY			
		Motor power (kW)	Motor power (hp)	I(A) Rated	Motor power (kW)	Motor power (hp)	I(A) Rated	
1	SD75K0160 6BCD	132	200	160	110	150	130	195
	SD75K0180 6BCD	160	250	180	132	200	150	225
	SD75K0210 6BCD	200	300	210	160	250	170	255
2	SD75K0250 6BCD	250	350	250	200	300	210	315
	SD75K0310 6BCD	315	400	310	250	350	260	390
3	SD75K0400 6BCD	355	450	400	315	400	320	480
	SD75K0480 6BCD	450	600	480	355	450	385	578
4	SD75K0570 6BCD	560	700	570	450	600	460	690
	SD75K0680 6BCD	630	900	680	560	700	550	825
>4 ^[1]	SD75K0825 6BCD	800	1000	825	630	900	660	990
	SD75K0930 6BCD	900	1200	930	800	1000	750	1125
	SD75K1050 6BCD	1000	1400	1050	900	1200	840	1260
	SD75K1200 6BCD	1200	1600	1200	1000	1400	950	1425
	SD75K1400 6BCD	1400	1800	1400	1200	1600	1140	1710
	SD75K1550 6BCD	1500	2000	1550	1400	1800	1270	1905
	SD75K1750 6BCD	1700	2200	1750	1500	2000	1420	2130
	SD75K1850 6BCD	1800	2400	1850	1700	2200	1500	2250
	SD75K2200 6BCD	2100	2750	2200	1800	2400	1800	2700
	SD75K2500 6BCD	2200	3000	2500	2100	2750	2000	3000

DIMENSIONS AND WEIGHTS

FRAME	W	D	H	WEIGHT (kg)
IP00				
1	312	400	1085	78,2
2	509	400	1085	148
3	759	400	1085	200
4 ^[1]	1009	400	1088	280
IP20				
1	310	400	1340	85,5
2	525	400	1341	159
3	759	400	1343	215,3
4 ^[1]	1025	400	1343	299,7

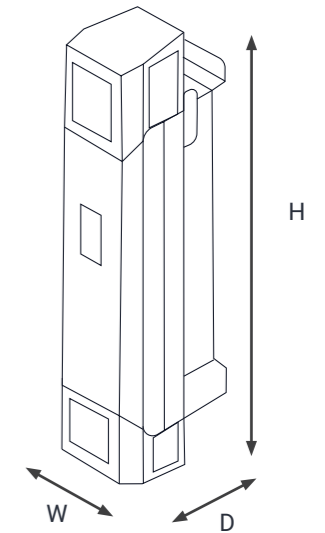

FRAMES 1 TO 4

IP00

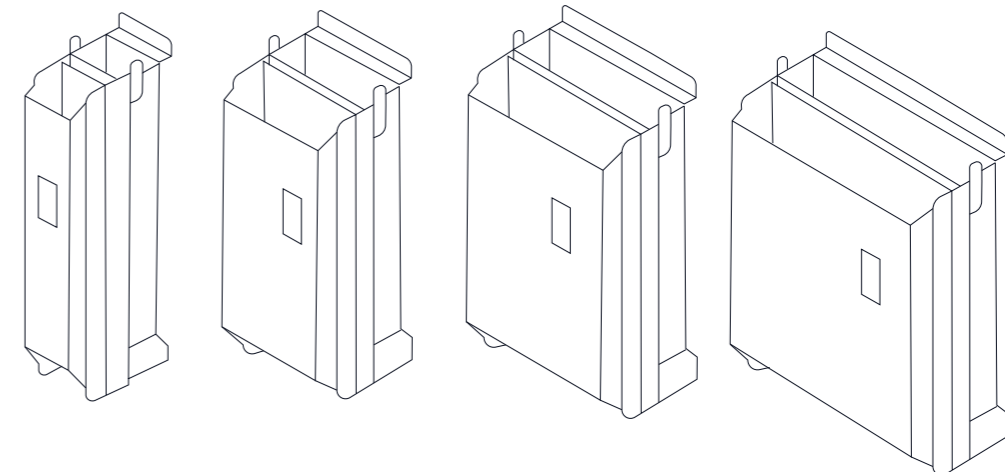

IP20

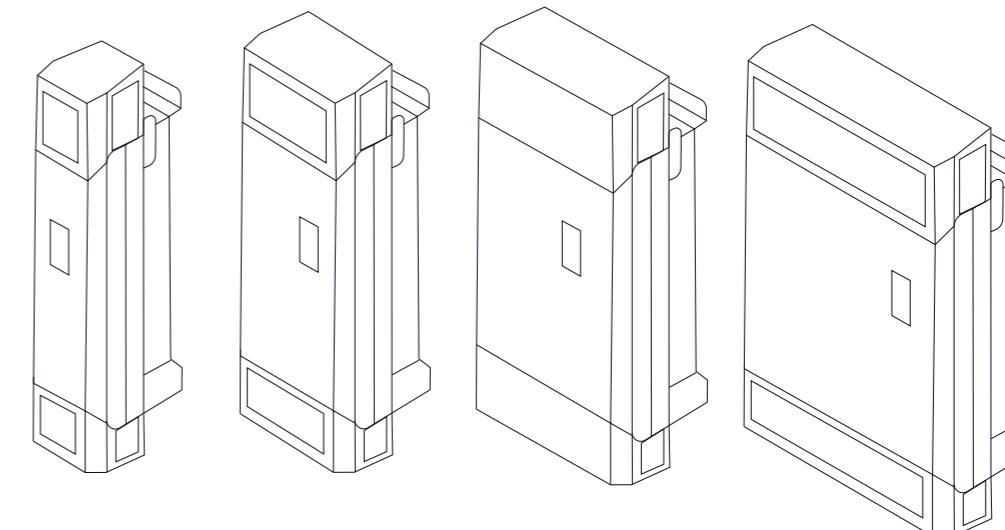

ACCESORIES

SD750 through its accessories fulfils the most extended requirements of the industrial sector. SD750 series offers a wide variety of communication protocols, dedicated boards, filters, interface accessories, etc... that enhances family features.

CODE	DESCRIPTION
SD75ET	Ethernet/IP communication board
SD75PN	Profinet communication board
SD75PB	Profibus communication board
SD75EC	Encoder board It allows to have 1 Differential Encoders (TTL or HTL) working from 5 to 24Vdc
SD75DIO	Digital input/outputs expansion boards It allows to increase the number of inputs and outputs of the unit. It includes: • 5 Digital Inputs optically isolated and configurable • 5 Digital Outputs (Relays)
SD75AIO	Analogue inputs/outputs expansion boards It allows to increase the number of inputs and outputs of the unit. It includes: • 2 Configurable analogue inputs • 2 Configurable analogue outputs
SD75FO	Fibre optics board. It allows to communicate several drives in master-slave configuration
SD75PT	Card for 8 thermal sensors type PT100 or PT1000 (configurable)
B150	Dynamic brake
SD75DE3	Display extender kit 3 meters

COMMUNICATIONS ACCESSORIES

SD750 series is compatible with the most commonly used communication protocols (Profibus, Profinet, Ethernet/IP...), thanks to its optional boards.

Fibre Optics Board

It connects and synchronizes all required drives through fibre optics.

Power Motor Control can be utilised with the master and multiple followers all sharing identical torque or following the same speed reference. The fibre optics allows long communication distance without interference.

EXTENSION BOARDS

I/O Expander Board

Optionally, the SD750 has two input and output expansion boards available, which allow the converter to be integrated in any type of installation:

Digital expansion boards:

- 5 digital inputs
- 5 digital outputs

Analogue expansion boards:

- 2 analogue inputs (0-10V, 4-20mA)
- 2 analogue outputs

Encoder Board

The encoder board improves the speed regulation thanks to the closed loop control. They are optically isolated and have the possibility to be powered by 5Vdc or 24Vdc.

PT100 Input Expander

The PT100 board provides extra protection to the motor, guaranteeing the correct operation of the motor and the application. It allows connecting up to 8 PT100 sensors in the equipment, permitting the monitoring of different temperature sensors installed in the motor, or even for temperature process control.

MECHANICAL ACCESSORIES

IP20 Connection Boxes

SD750 frames 1 to 3 have extension boxes permitting larger cables to be terminated.

FRAME	CODE	DIMENSIONS		
		W	D	H
1	SD75EB1	189	122	161
2	SD75EB2	295	122	161
3	SD75EB3	300	151	168

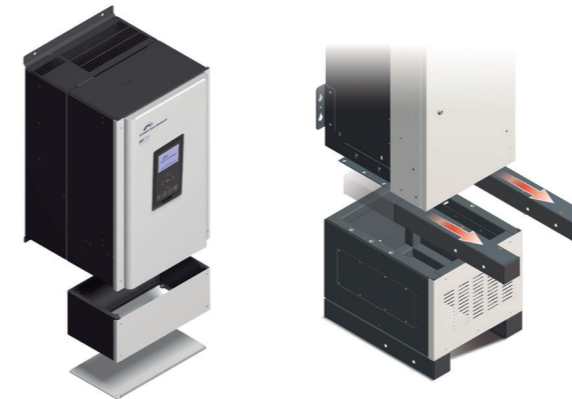

SD750 Frame 4 to 8 plinths

SD750 frames 5 and up are stand-alone drives. They can be equipped with optional plinths to attain 2000mm or 2200mm total height. A stand-alone plinth for frame 4 attaining total height of 1712mm is also available.

FRAME	CODE	DIMENSIONS			Total drive height (mm)
		W	D	H	
4	SD75PL0417	320	464	438.5	1712
	SD75PL0420	320	464	468.5	2000
5	SD75PL0520	431	413.5	529	2000
	SD75PL0522	431	613.5	529	2200
6	SD75PL0620	786	413.5	529	2000
	SD75PL0622	786	613.5	529	2200
7	SD75PL0720	1132	413.5	529	2000
	SD75PL0722	1132	613.5	529	2200
8	SD75PL0820	1482	413.5	529	2000
	SD75PL0822	1482	613.5	529	2200

OTHER ACCESSORIES

Dynamic brake B150

The Dynamic brake controls the regenerated energy for SD750 series. B150 dynamic brake activates an IGBT to discharge the DC bus through external resistors when the DC voltage surpasses a pre-set value.

This activation signal could also be delivered by the drive acquiring an optional Master-Slave mode braking board.

REFERENCE	VOLTAGE	Current (A)		Minimum Resistance Rating (Ω)	Dimensions (mm)			Weight (kg)
		Maximum	Continuous		W	D	H	
B150	380Vac, 500Vac	300A	150A	2.4Ω	177	221	352	7
B150.6	690Vac	200A	100A	5.75Ω				



Special filters

Special output and input filters are available such as sinusoidal output filter or First Environment, C2 category input filter. For further information consult Power Electronics.

Painting

SD750 can include special cabinet painting. Customized solutions available.

Safety

SD750 can include safety accessories such as PT100, emergency off and emergency stop pushbuttons.

POWER SUPPORT

BY POWER ELECTRONICS

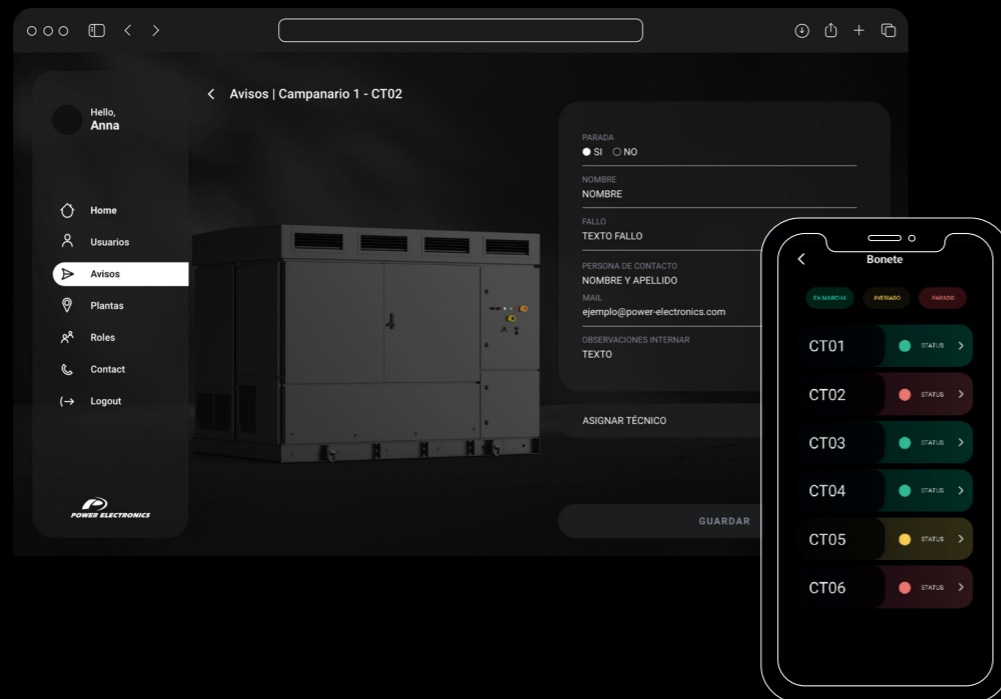

Our secret

The key of our success for more than **30 years**, our **24/7 after sales service**, **Power On Support**.

We take care of the legacy generations

Each new generation of inverters involves adapting the manufacturing lines to optimize the production of these new devices. Power Electronics has a facility optimized for the production of limited units from previous generations, where we manufacture current subcomponents adapted to equipment that is no longer in production, but which allows for an extended life.

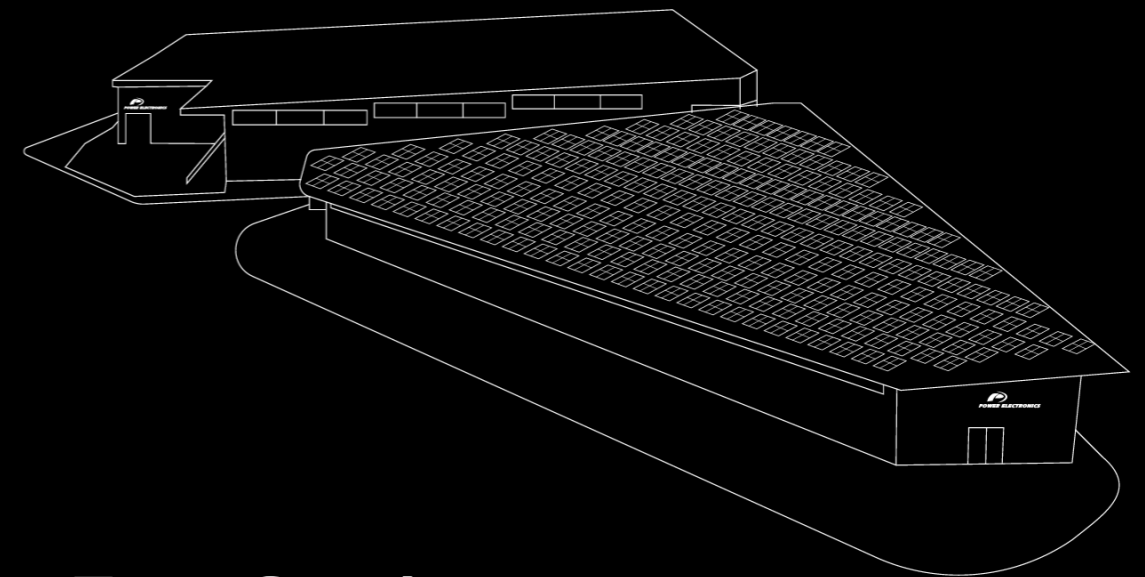
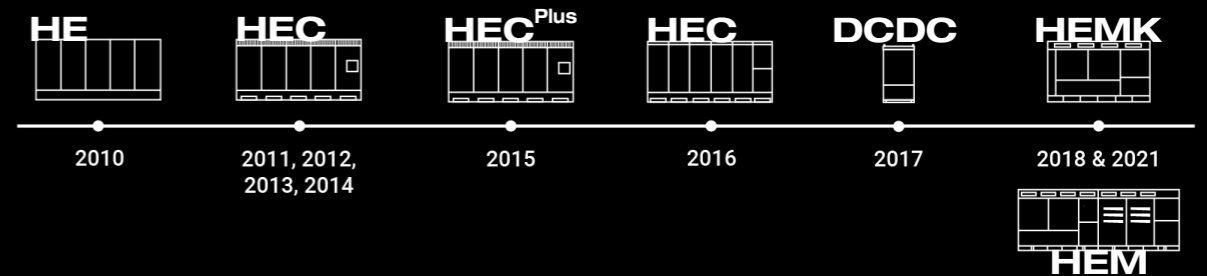

Long Term Service

We repair subcomponents or even manufacture equivalent units in our **Dedicated Service Factory** located near our **Production Plant**.

Power Electronics has experience in repowering old photovoltaic plants, where we supply state-of-the-art equipment adapting its electrical characteristics to be compatible with the existing configuration, while providing all the advantages of the latest generation inverters.

Vertical Integration

throughout the entire process

We complement your spare parts strategy with our own thanks to our *Dedicated Service Factory* warehouse, informing you when any of them is going to be discontinued so you can plan accordingly.

↓ ↓ ↓
We are here to help you



Scan me!

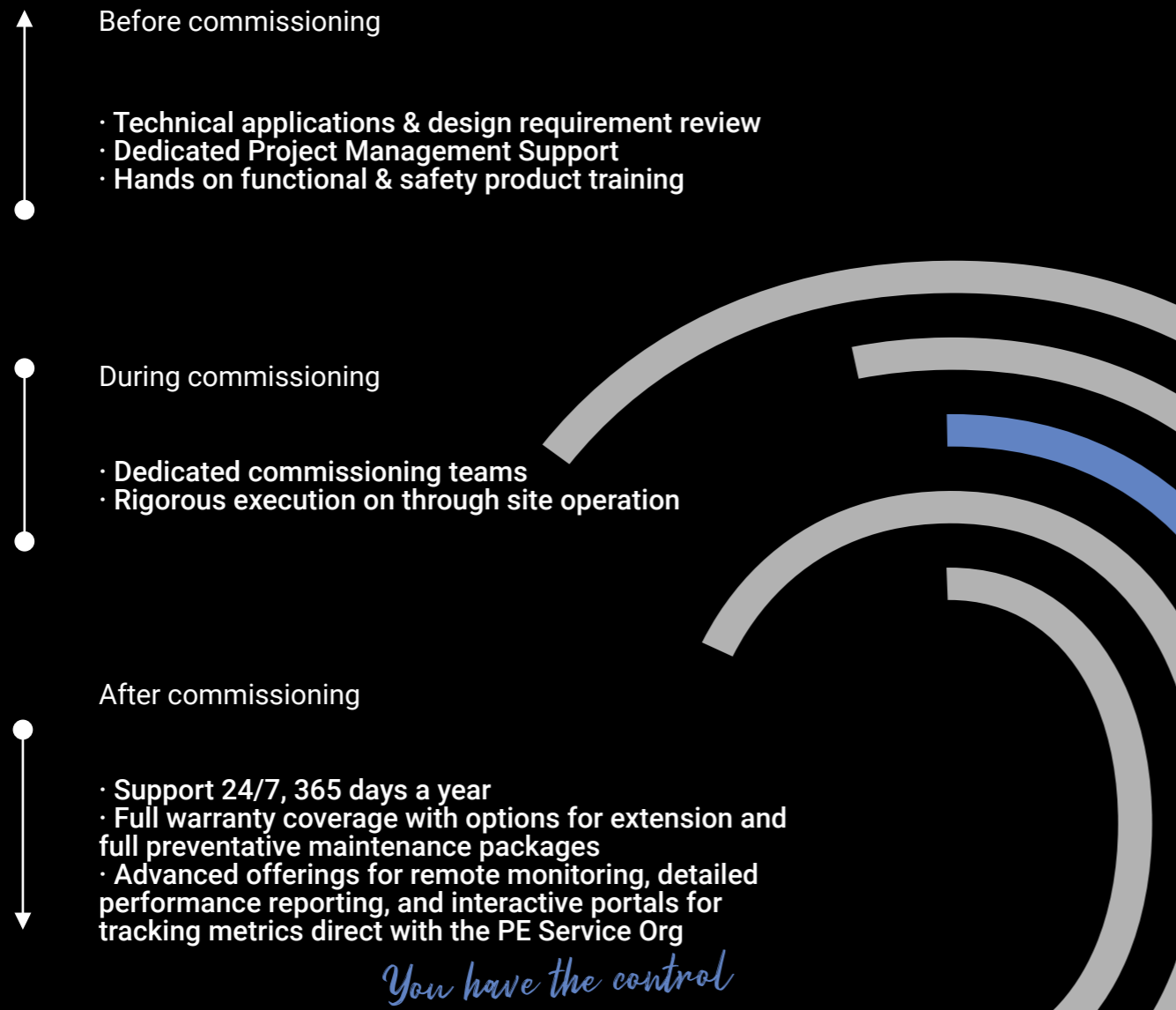

WARRANTY

Power Electronics (the Seller) warrants that their Products are free of faults and defects for a period of 3 years, valid from the date of delivery to the Buyer. It shall be understood that a product is free of faults and defects when its condition and performance is in compliance with its specification.

The warranty shall not extend to any Products whose defects are due to (i) careless or improper use, (ii) failure to observe the Seller's instructions regarding the transport, installation, functioning, maintenance and the storage of the Products, (iii) repairs or modifications made by the Buyer or third party without prior written authorization of the Seller, (iv) negligence during the implementation of authorized repairs or modifications, (v) if serial numbers are modified or illegible, (vi) anomalies caused by, or connected to, the elements coupled directly by the Buyer or by the final customer, (vii) accidents or events that place the Product outside its storage and operational specification, (viii) continued use of the Products after identification of a fault or defect.

The warranty excludes components that must be replaced periodically such as Fuses + DC switch, lamps & air filters or consumable materials subject to normal wear and tear.

The warranty excludes external parts that are not manufactured by the Seller under the brand of Power Electronics.

The Seller undertakes to replace or to repair, himself, at their discretion, any Product or its part that demonstrates a fault or defect, which is in conformance with the aforementioned terms of the warranty. Reasonable costs associated with the disassembly/ assembly, transport and customs of equipment will also be undertaken by the Seller except in cases of approved intervention by the Buyer and/or their representative where cost allocation has been previously agreed.



Power Electronics reserves the right to modify whole or part of the content of this brochure at any time and without prior notice. May 2021.

HEADQUARTERS

SPAIN

Polígono Pla de Carrases
CV-35 Exit 30, 46160
Liria - Valencia - Spain
Tel. (+34) 96 136 65 57
Fax (+34) 96 131 82 01
24/7 Technical Assistance Service
Tel. (+34) 902 40 20 70

UNITED STATES

1510 N. Hobson Street, Gilbert
Arizona, USA
Tel. (+001) 602-354-4890
sales@power-electronics.us
24/7 Technical Assistance Service
Tel. (+001) 902 40 20 70

INTERNATIONAL

ARGENTINA

Arroyo 894, 5°
Oficina 10 Ciudad autónoma de
Buenos Aires

ASIA

30th Floor, CATIC Plaza, 8 Cau-
seway Road, Hong Kong SAR

AUSTRALIA

U6, 30-34 Octal St. Yatala, Brisbane,
Queensland 4118, Australia
(+61) 7 3386 1993
sales@power-electronics.com.au

BEIJING

Xiaoying Road Chaoyang, N°25,
Beijing City

BRAZIL

Avda. Robert Kennedy 2070. Sao Bernardo do
Campo. Sao Paulo
(+55) 11 5891 9612 / (+55) 11 5891 9762
brasil@power-electronics.com
Contact: Fabio Cinquini

CHILE

Av. Alonso de Córdova 5870, Of. 210-211
Las Condes, Santiago de Chile
(+56) 2 3223 8916
ventaschile@power-electronics.com

COLOMBIA

Cl 77 9-20 Bogotá DC
Colombia
(+57) 322 3464855
colombia@power-electronics.com
Contact: Héctor Nuñez

FRANCE

51 Rue Hoche, 94200 Ivry Sur Seine.
Paris (France)
+33(0)1 46 46 10 34
ventesfrance@power-electronics.com
Contact: Guillaume Mamy

INDIA

Silver Jade, Off. No 03, G.F., A-Wing CTS NO.
-188, Behind Tarun Bharat Society, Chakala,
Andheri East, Mumbai, Maharashtra
(+91) 80 6569 0489
india@power-electronics.com

ITALIA

Piazzale Cadorna, 6, 20123.
Milán Italia
italy@power-electronics.com

JAPAN

Nishi-Shinbasi 2-17-2 HF Toranomom Bldg 5F.
105-0003 Minato-Ku Tokio
japan@power-electronics.com
Contact: Stanley Han

MALAYSIA

Level 7, Menara Milenium, Jalan Damanlela,
Pusat Bandar Damansara, Damansara
Heights, 50490 Kuala Lumpur W.P.
Malaysia
malaysia@power-electronics.com

MEXICO

Henry Ford n.3, Fraccionamiento Industrial
San Nicolás, Tlalnepantla, Estado de México
(+52) 1 55 4949 0830 / (+52) 539 08818
mexico@power-electronics.com
Contact: Manuel Garay

PERU

Avenida El Polo n° 670, Centro Comercial
El Polo II – Oficina 603, Piso 6°, Bloque C
Santiago de Surco, Lima
(+51) 979 749 772
ventasperu@power-electronics.com
Contact: Gustavo Prialé

GERMANY

Deieselstrasse, 77. D-90441.
Nürnberg. Germany
germany@power-electronics.com

SOUTH AFRICA

Central Office Park Unit 5
257 Jean Avenue – Centurion 0157
southafrica@power-electronics.com

UNITED KINGDOM

Chippenham Drive, Unit 2, Madingley Court.
Kingston, Milton Keynes.
MK10 0BZ, United Kingdom
uksales@power-electronics.com
Contact (Solar division): Juan Antonio Torres

PHILIPPINES

Unit 209 ZF Page 1 Bldg MBP
Ayala Alabang, Muntinlupa.

REPÚBLICA DOMINICANA

Ave. John F. Kennedy Núm. 7, Los Jardines,
Distrito Nacional, República Dominicana.

IRELAND

20 Harcourt Street Dublin,
D02 H364, Irlanda



March 2022
www.power-electronics.com

